

VAREZ 125

Ed. 01-2020



VAREZ



Catalogo ricambi
Spare parts catalog
Catalogue pieces de rechange
Ersatzteilkatalog
Catalogo piezas de repuestos

INFORMAZIONI GENERALI

Il presente catalogo serve per richiedere con esattezza le parti di ricambio
Nelle ordinazioni indicare:

- 1) il numero di codice dei particolari seguito dalla descrizione;
- 2) il colore per i pezzi verniciati o comunque colorati;
- 3) il numero di matricola del motociclo, stampigliato sul canotto di sterzo.

Le indicazioni destra e sinistra si riferiscono ai lati del veicolo rispetto al senso di marcia;

Dati indicativi soggetti a modifiche senza impegno di preavviso.
All data are subject to modification without prior notice.
Données indicatif sujet au modifications sans obligation de préavis.
Anderungen Vorbehalten.
Datos indicativos sujetos a modificaciones sin compromiso de preaviso.

GENERAL INFORMATION

The present spare parts list enables one to order exactly the right spare parts.
When ordering specify:

- 1) the part's code number followed by its description;
- 2) indicate colour for painted or coloured parts;
- 3) the motorcycle's serial number, stamped on the steering head.

References to right and left apply to the vehicle in terms of its direction of movement.

NOTE - LIST - NOTES - NOTE - NOTAS:

AUS : Australia, Australia, Australie, Australien, Australia
 CDN : Canada, Canada, Canada, Kanada, Canadá
 IT : Italia, Italy, Italie, Italien, Italia
 JAP : Giappone, Japan, Japon, Japan, Japón
 USA : Stati Uniti d'America, United States of America, Etats Units d'Amerique,
 Vereinigte Staaten von Amerika, Estados Unidos

INFORMATIONS GENERALES

Ca catalogue permet de commander correctement les pièces de rechange.
Les commandes doivent être passées en indiquant:

- 1) le numéro de code des pièces détachées suivi de leur description;
- 2) le couleur des pièces peintes ou colorés;
- 3) le matricule de la moto, estampillé sur la tige du guidon.

Droite et gauche sont les côtés du véhicule par rapport au sens de la marche.

ALLGEMEINE HINWEISE

Dieser Ersatzteilkatalog dient zur genauen Angabe der Teile bei
Ersatzteilbestellungen.

Bei Ersatzbestellung ist folgendes anzugeben:

- 1) Die Bestellnummer der Ersatzteile mit der entsprechenden Beschreibung;
- 2) Farbe für lackierte und farbige Teile angeben;
- 3) Die Sseriennummer des Motorrads, die am Lenkrohr eingepreßt ist.

Die Angaben rechts und links beziehen sich auf das Fahrzeug in Fahrriichtung.

INFORMACIONES GENERALES

El presente catálogo sirve para pedir con exactitud las partes de recambio.
En los pedidos se debe indicar:

- 1) el número de código de la parte y a continuación la descripción;
- 2) el color para las piezas barnizadas o coloreadas;
- 3) el número de matrícula de la motocicleta, estampado en le tubo de dirección.

Las indicaciones derecha e izquierda se refieren a los lados del vehículo respecto del sentido de marcha.

N° DI MATRICOLA INIZIALE - INITIAL SERIAL NUMBER - MATRICULE INITIAL - BEGINNTESEIENNUMMER - MATRICULA INICIAL	
MODELLO - MODEL MODELE - MODELL MODELO	MATRICOLA - SERIAL NUMBER MATRICULE - SERIENNUMMER MATRICULA
VAREZ	ZNOB300AEKV000000



INDICE – INDEX – INDEX – INHALTSVERZEICHNIS – INDICE

VAREZ 125

Tavola Drawing Table Bild Tabla	Denominazione	Description	Designation	Bezeichnung	Denominacion	Pagina Page Seite Paja
1	ATTREZZI DI ASSISTENZA, MANUALI E DOTAZIONI	SERVICE TOOLS, MANUALS AND EQUIPMENT	OUTILS D'ASSISTANCE, MANUELS ET EQUIPEMENT	HILFAUSRUSTUNG, HANDBUCH UND DOTIERUNG	HERRAMIENTAS DE ASISTENCIA, MANUALES Y EQUIPAMIENTO	12
2	CILINDRO, PISTONE	CYLINDER, PISTON	CYLINDRE, PISTON	ZYLINDER, KOLBEN	CILINDRO, PISTON	14
3	TESTA CILINDRO	CYLINDER HEAD	CULASSE	ZYLINDERKOPF	CULATA	16
4	COPERCHIO VALVOLE	VALVE COVER	COUVERCLE CULASSE	ZYLINDERKOPFDECKEL	TAPA CULATA	18
5	MANOVELLISMO	CRANKSHAFT	VILEBREQUIN	KURBELWELLE	CIGÜEÑAL	20
6	DISTRIBUZIONE	VALVE TIMING	DISTRIBUTION	VENTILSTEUERUNG	DISTRIBUCION	22
7	LUBRIFICAZIONE	OIL PUMP	PUMPE HUILE	MOTORSCHMIERUNG	LUBRICACION	24
8	COPERCHIO CARTER SINISTRO	LEFT CRANKCASE COVER	COUVERCLES CARTER GAUCHE	GEHAUSEDECKEL LINKS	TAPAS BANCADA IZQUIERDA	26
9	SEMICARTER SINISTRO	LEFT HALF CRANKCASE	CARTER GAUCHE	GEHAUSEDECKEL LINKS	BANCADA IZQUIERDA	28
10	SEMICARTER DESTRO	RIGHT HALF CRANKCASE	CARTER DROIT	GEHAUSEDECKEL RECHTS	BANCADA DERECHO	30
11	FRIZIONE	CLUTCH	EMBAYAGE	KUPPLUNG	EMBRAGUE	32
12	COMANDO CAMBIO	GEARSHIFT MECHANISM	COMMANDE DE VITESSE	GANGSCHALTUNG	MANDO CAMBIO	34
13	PARTE ELETTRICA	IGNITION SISTEM	PARTIES ELECTRIQUE	ELEKTRISCHE TEILE	PARTE ELECTRICA	36
14	AVVIAMENTO	STARTING	DEMARRAGE	ANLASSER	ARRANQUE	38
15	CORPO FARFALLATO	THROTTLE BODY	CORP PAPILLON	DROSSELKLAPPENKÖRPER	CUERPO OSCILANTE	40
16	FILTRO ARIA	AIR FILTER	FILTRE AIRE	LUFTFILTER	FILTRO DE AIRE	42
17	IMPIANTO DI RAFFREDDAMENTO	COOLING SYSTEM	INSTALLATION RAFROIDISSEMENT	SCHMIERUNGSSYSTEM	EQUIPO DE ENFRIAMIENTO	44
18	SERBATOIO CARBURANTE	FUEL TANK	RESERVOIR CARBURANT	KRAFTSTOFFBEHALTER	DEPOSITO GASOLINA	48
19	SELLE - PANNELLI POSTERIORI - PORTATARGA	SEATS - REAR PANEL - PLATE HOLDER	SELLES - PANNEAUX ARRIÈRE - SUPPORT DE PLAQUE D'IMMATRICULATION	SITZBÄNKE - HINTERE VERKLEIDUNGSTEILE - KENNZEICHENHALTER	ASIENTOS - PANELES TRASEROS - PORTAMATRÍCULA	52
20	PANNELLI, PARAFANGHI	PANEL, FENDERS	PANNEAU, GARDE-BOUES	STREIFEN, KOTFLUGEL	PANELO, GUARDABARROS	54
21	TELAIO, PEDANE	FRAME, FOOT RESTS	CADRE, REPOSE PIEDS	RAHMEN, FUSSBRETT	REPOSAPIES Y MANILLA ACOMPAÑANTE	56
22	MANUBRIO E COMANDI	HANDLEBAR AND CONTROLS	GUIDON ET COMMANDES	LENKER UND STEUERORGANE	MANILLAR Y MANDOS	60
23	SOSPENSIONE ANTERIORE	FRONT FORK ASSEMBLY	SUSPENSION AVANT	VORDETELESKOPGABEL	SUSPENSION DELANTERA	62
24	AMMORTIZZATORE POSTERIORE	REAR SUSPENSION	SUSPENSION ARRIERE	HINTERHAUFHANGUNG	SUSPENSION TRASERA	64
25	LEVERAGGI SOSPENSIONE POSTERIORE	REAR SUSPENSION LINKAGE	LEVIER SUSPENSION ARRIERE	HEBELWERK HINTERHAUFHANGUNG	PLANCA SUSPENSION TRASERA	66
26	FORCELLONE POSTERIORE	REAR SWING ARM	FOURCHE ARRIERE	HINTERGABEL	HORQUILLA TRASERA	68
27	RUOTA ANTERIORE	FRONT WHEEL	ROUE AVANT	VORTERRAD	RUEDA DELANTERA	70
28	RUOTA POSTERIORE	REAR WHEEL	ROUE ARRIERE	HINTERRAD	RUEDA TRASERA	72
29	FRENO IDRAULICO ANTERIORE	FRONT HYDRAULIC BRAKE	FREIN HYDRAULIQUE AVANT	VORDERBREMSE	FRENO HIDRAULICO DELANTERO	74
30	FRENO IDRAULICO POSTERIORE	REAR HYDRAULIC BRAKE	FREIN HYDRAULIQUE ARRIERE	HINTERBREMSE	FRENO HIDRAULICO TRASERO	76



INDICE – INDEX – INDEX – INHALTSVERZEICHNIS - INDICE

VAREZ 125

Tavola - Drawing - Table - Bild - Tabla

1

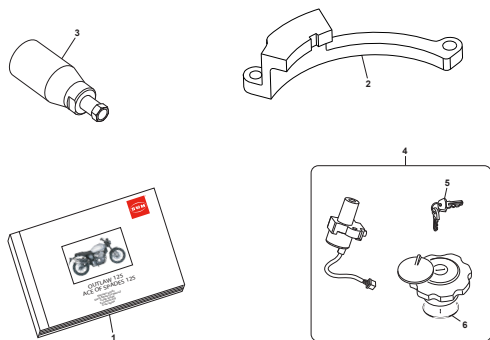

Pagina - Page - Page - Seite - Paja

12

Tavola - Drawing - Table - Bild - Tabla

2

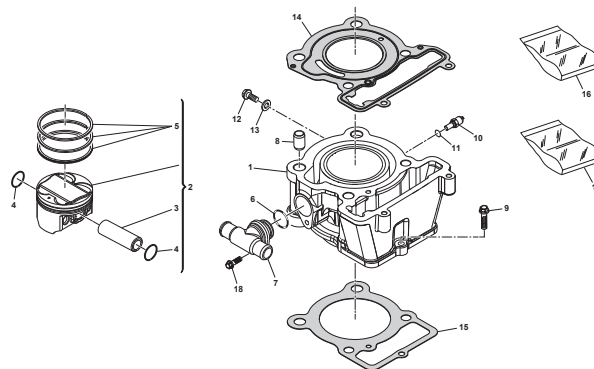

Pagina - Page - Page - Seite - Paja

14

Tavola - Drawing - Table - Bild - Tabla

3

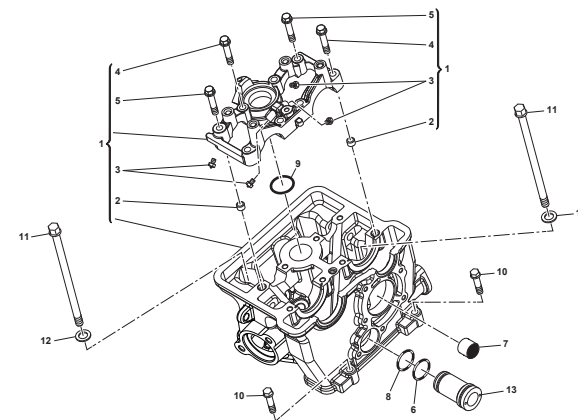

Pagina - Page - Page - Seite - Paja

16

Tavola - Drawing - Table - Bild - Tabla

4

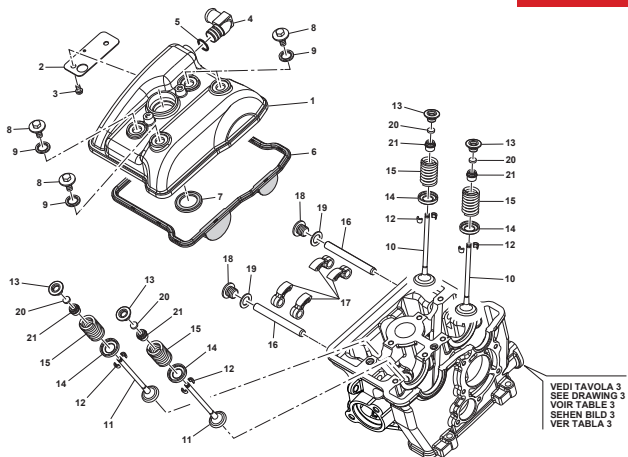

Pagina - Page - Page - Seite - Paja

18

Tavola - Drawing - Table - Bild - Tabla

5

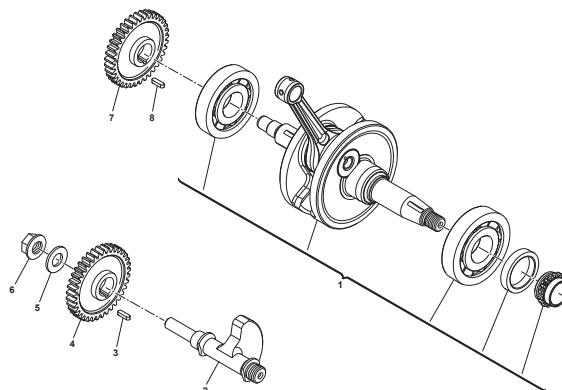

Pagina - Page - Page - Seite - Paja

20

Tavola - Drawing - Table - Bild - Tabla

6

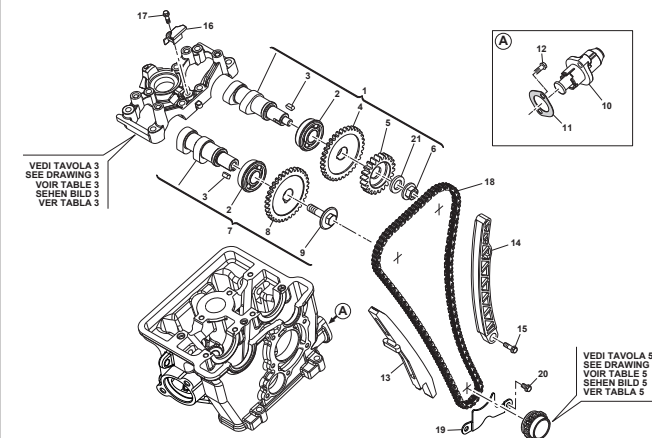

Pagina - Page - Page - Seite - Paja

22

Tavola - Drawing - Table - Bild - Tabla

7

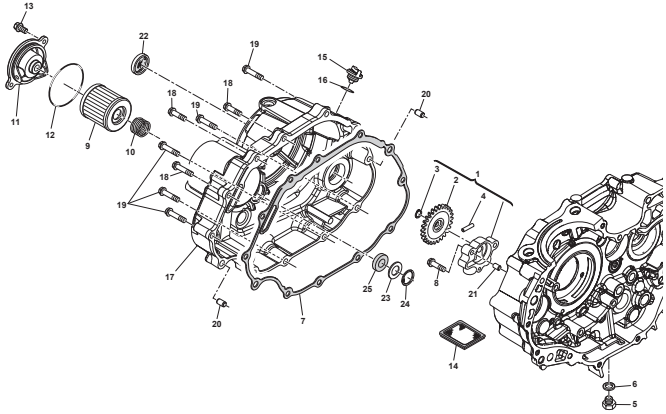

Pagina - Page - Page - Seite - Paja

24

Tavola - Drawing - Table - Bild - Tabla

8

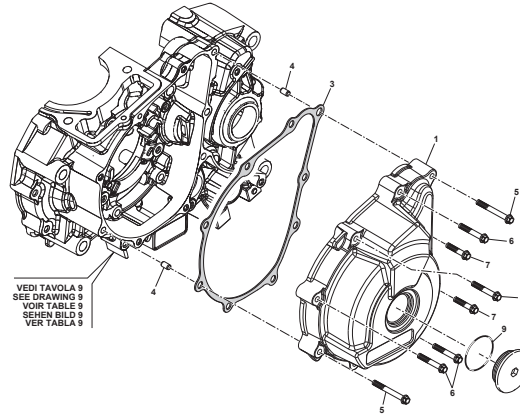

VEDI TAVOLA 9
SEE DRAWING 9
VOIR TABLE 9
SEHEN BILD 9
VER TABLA 9

Pagina - Page - Page - Seite - Paja

26

Tavola - Drawing - Table - Bild - Tabla

9

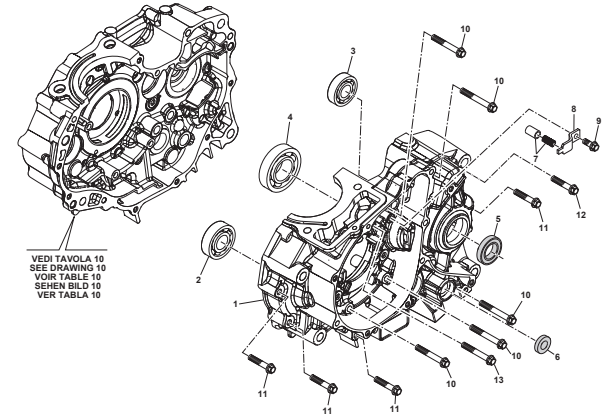

VEDI TAVOLA 10
SEE DRAWING 10
VOIR TABLE 10
SEHEN BILD 10
VER TABLA 10

Pagina - Page - Page - Seite - Paja

28

Tavola - Drawing - Table - Bild - Tabla

10

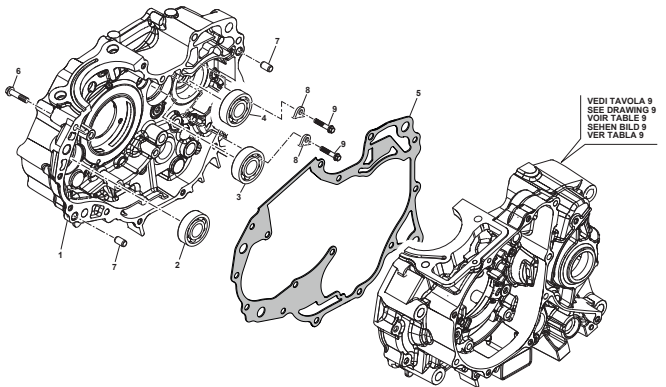

VEDI TAVOLA 9
SEE DRAWING 9
VOIR TABLE 9
SEHEN BILD 9
VER TABLA 9

Pagina - Page - Page - Seite - Paja

30

Tavola - Drawing - Table - Bild - Tabla

11

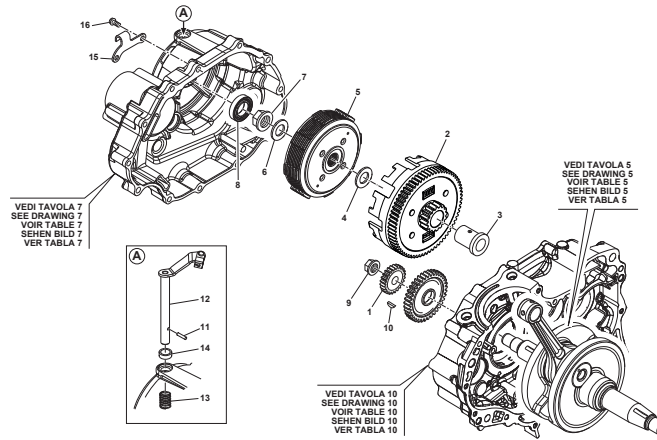

VEDI TAVOLA 7
SEE DRAWING 7
VOIR TABLE 7
SEHEN BILD 7
VER TABLA 7

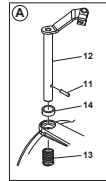

VEDI TAVOLA 10
SEE DRAWING 10
VOIR TABLE 10
SEHEN BILD 10
VER TABLA 10

VEDI TAVOLA 5
SEE DRAWING 5
VOIR TABLE 5
SEHEN BILD 5
VER TABLA 5

Pagina - Page - Page - Seite - Paja

32

Tavola - Drawing - Table - Bild - Tabla

12

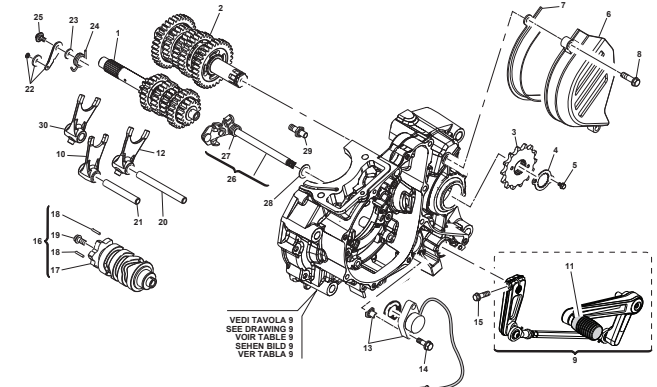

VEDI TAVOLA 9
SEE DRAWING 9
VOIR TABLE 9
SEHEN BILD 9
VER TABLA 9

Pagina - Page - Page - Seite - Paja

34

Tavola - Drawing - Table - Bild - Tabla

13

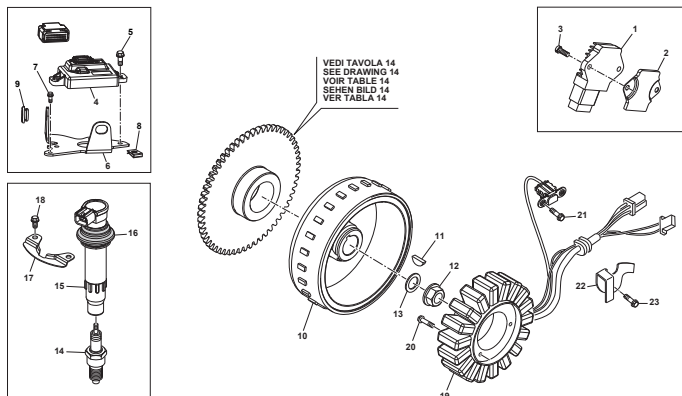

Pagina - Page - Page - Seite - Paja

36

Tavola - Drawing - Table - Bild - Tabla

14

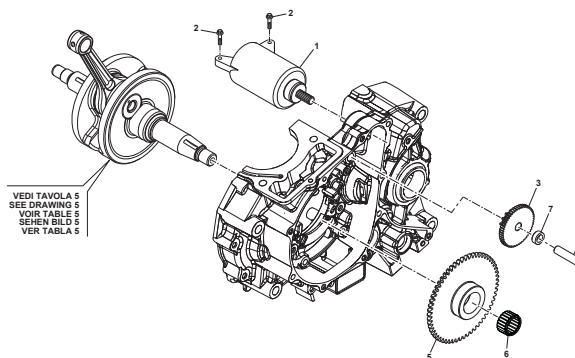

Pagina - Page - Page - Seite - Paja

38

Tavola - Drawing - Table - Bild - Tabla

15

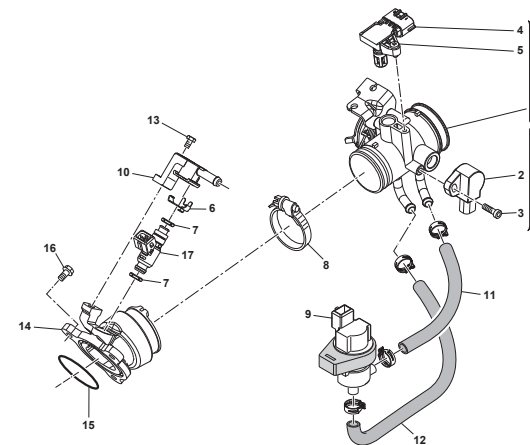

Pagina - Page - Page - Seite - Paja

40

Tavola - Drawing - Table - Bild - Tabla

16

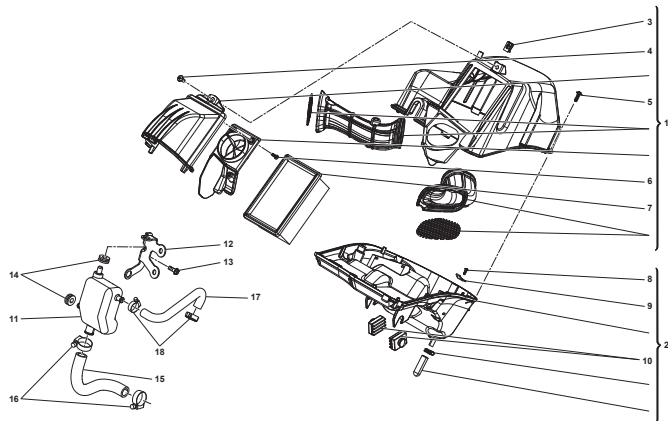

Pagina - Page - Page - Seite - Paja

42

Tavola - Drawing - Table - Bild - Tabla

17

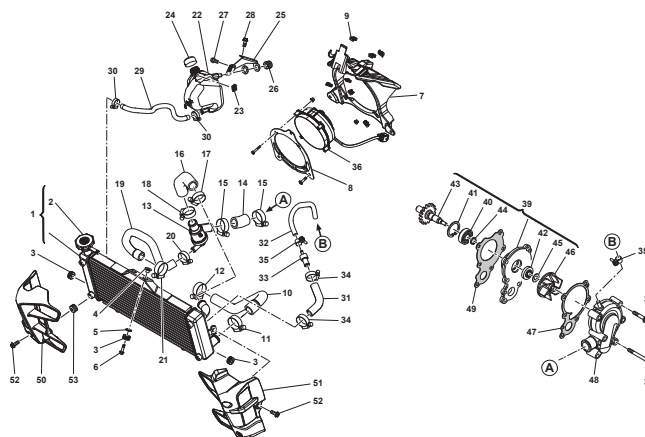

Pagina - Page - Page - Seite - Paja

44

Tavola - Drawing - Table - Bild - Tabla

18

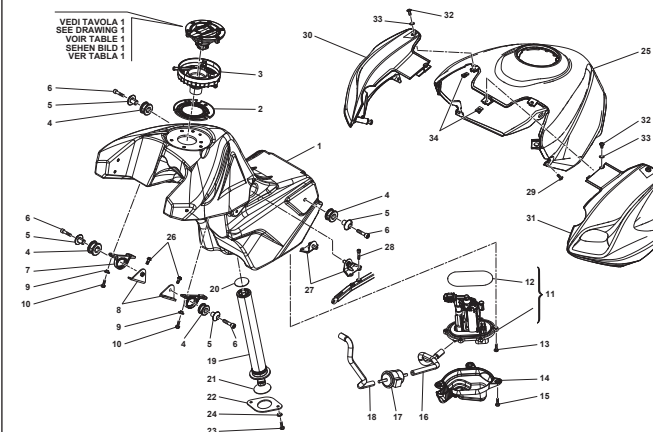

Pagina - Page - Page - Seite - Paja

48

Tavola - Drawing - Table - Bild - Tabla

19

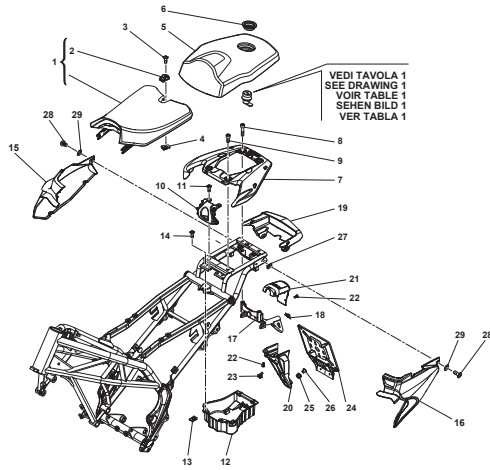

Pagina - Page - Page - Seite - Paja

52

Tavola - Drawing - Table - Bild - Tabla

20

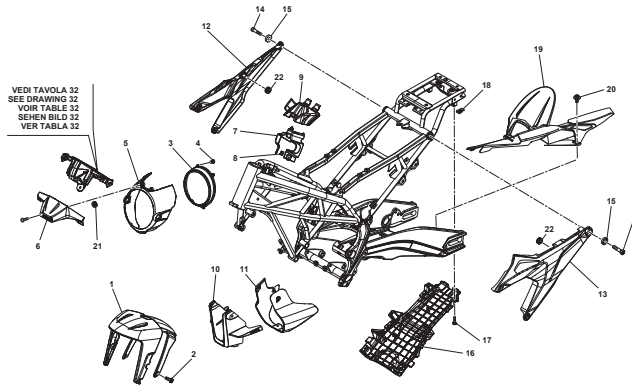

Pagina - Page - Page - Seite - Paja

54

Tavola - Drawing - Table - Bild - Tabla

21

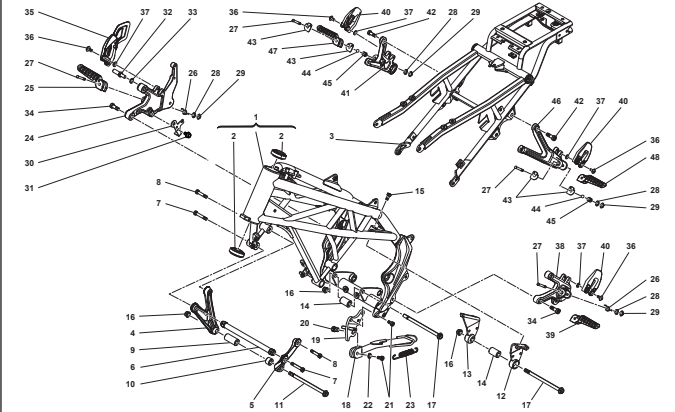

Pagina - Page - Page - Seite - Paja

56

Tavola - Drawing - Table - Bild - Tabla

22

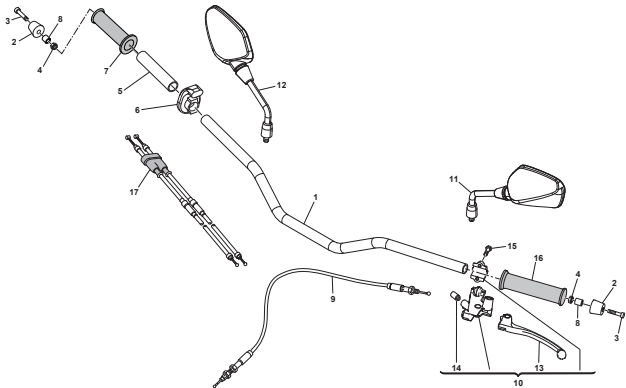

Pagina - Page - Page - Seite - Paja

60

Tavola - Drawing - Table - Bild - Tabla

23

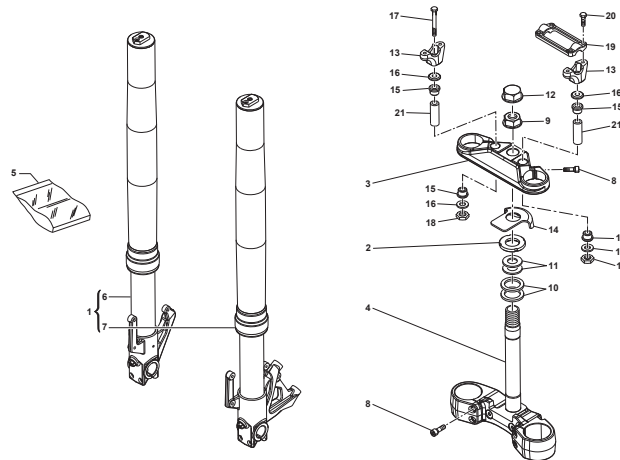

Pagina - Page - Page - Seite - Paja

62

Tavola - Drawing - Table - Bild - Tabla

24

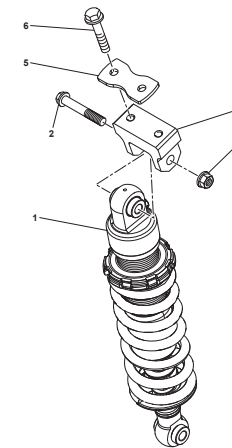

Pagina - Page - Page - Seite - Paja

64

Tavola - Drawing - Table - Bild - Tabla

25

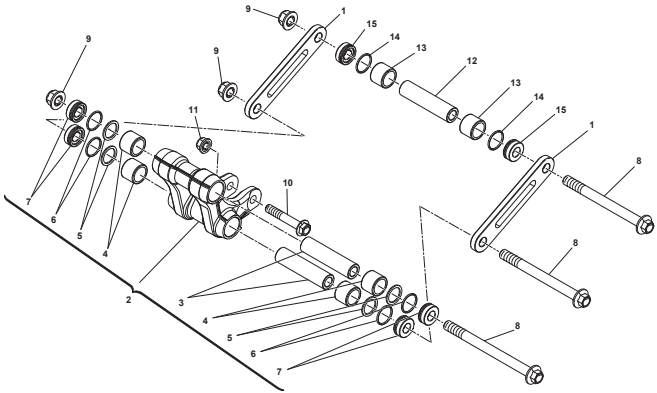

Pagina - Page - Page - Seite - Paja

66

Tavola - Drawing - Table - Bild - Tabla

26

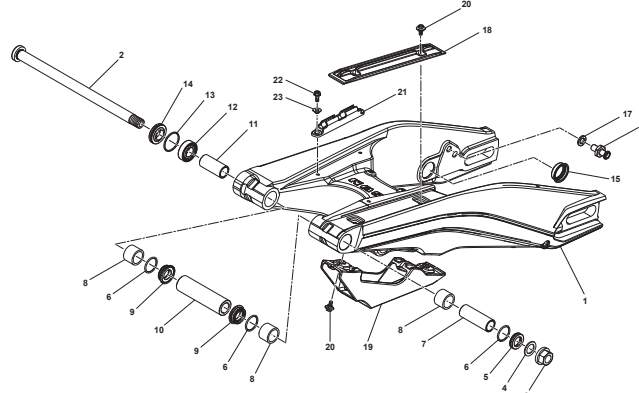

Pagina - Page - Page - Seite - Paja

68

Tavola - Drawing - Table - Bild - Tabla

27

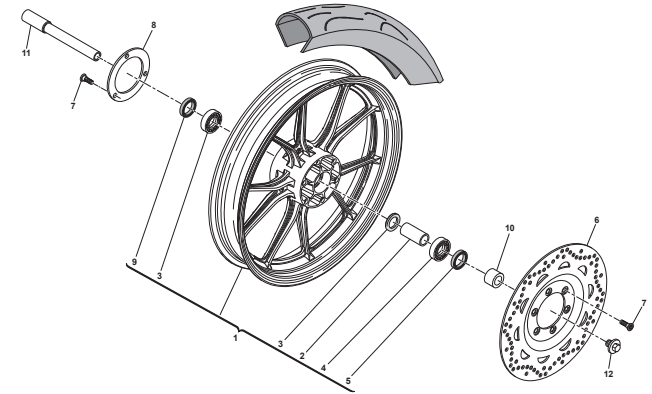

Pagina - Page - Page - Seite - Paja

70

Tavola - Drawing - Table - Bild - Tabla

28

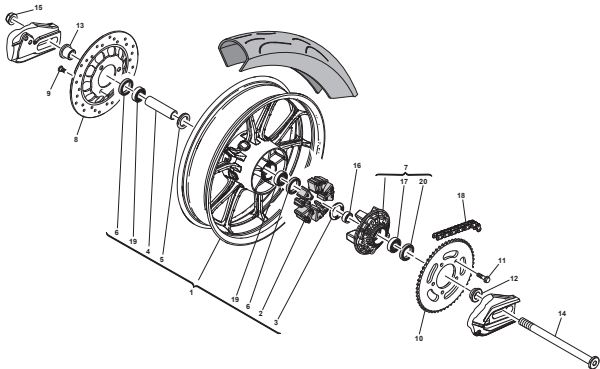

Pagina - Page - Page - Seite - Paja

72

Tavola - Drawing - Table - Bild - Tabla

29

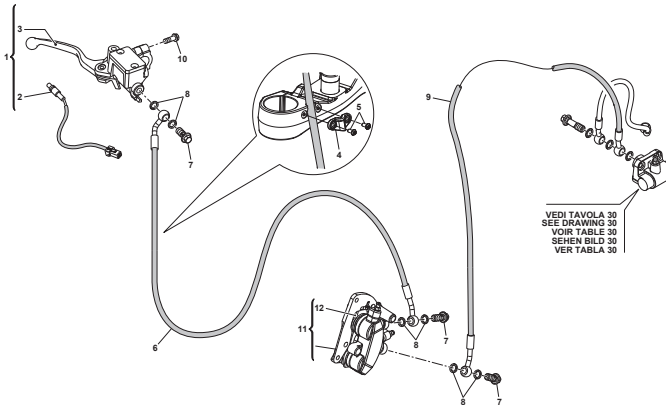

VEDI TAVOLA 30
SEE DRAWING 30
VOIR TABLE 30
SEHEN BILD 30
VER TABLA 30

Pagina - Page - Page - Seite - Paja

74

Tavola - Drawing - Table - Bild - Tabla

30

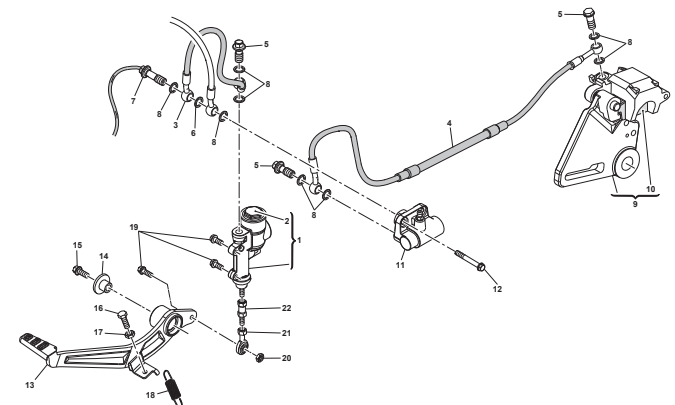

Pagina - Page - Page - Seite - Paja

76

Tavola - Drawing - Table - Bild - Tabla

31

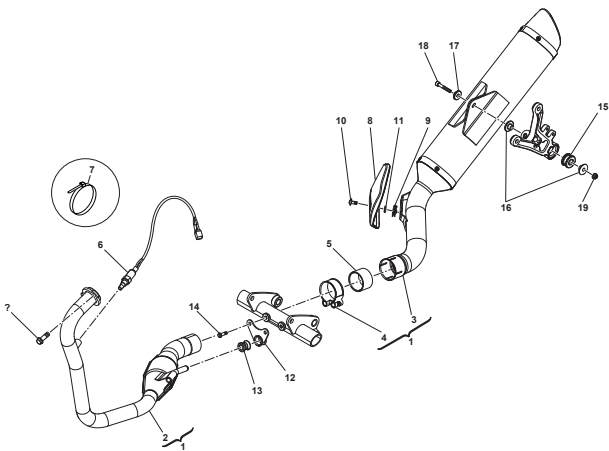

Pagina - Page - Page - Seite - Paja

78

Tavola - Drawing - Table - Bild - Tabla

32

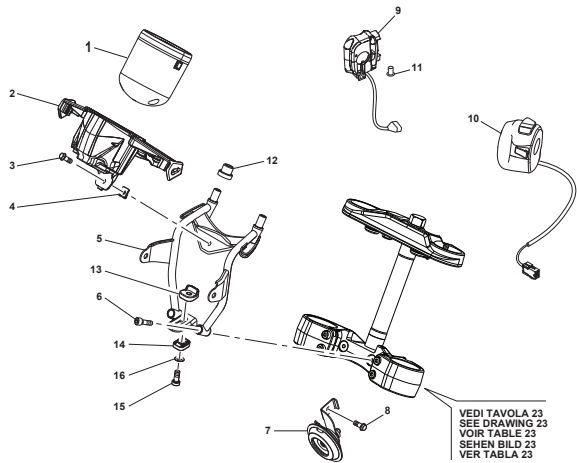

Pagina - Page - Page - Seite - Paja

80

Tavola - Drawing - Table - Bild - Tabla

33

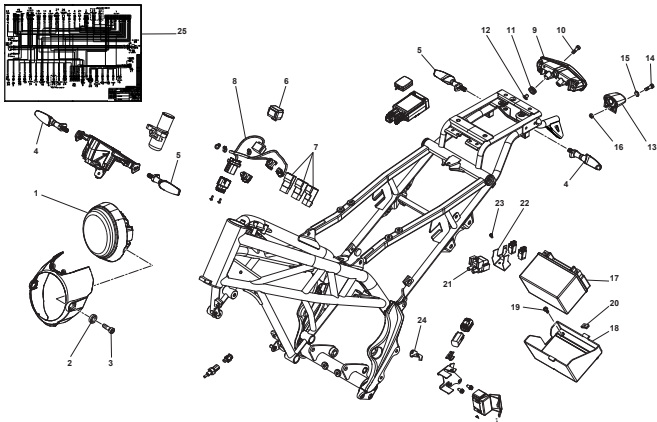

Pagina - Page - Page - Seite - Paja

82

Tavola - Drawing - Table - Bild - Tabla

34

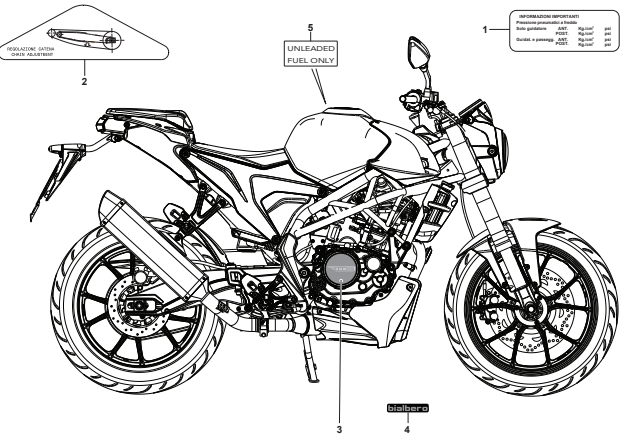

Pagina - Page - Page - Seite - Paja

84



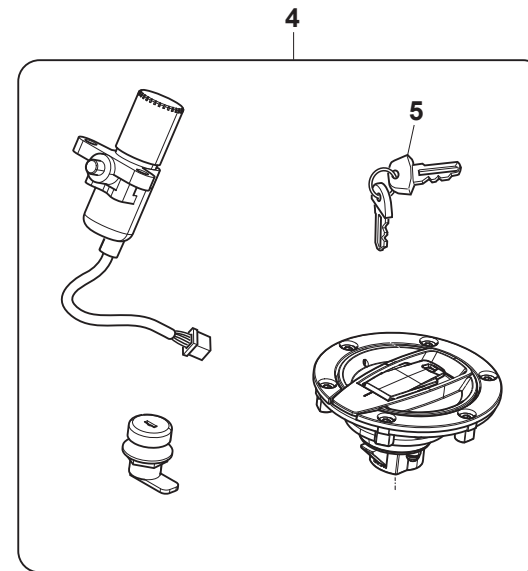
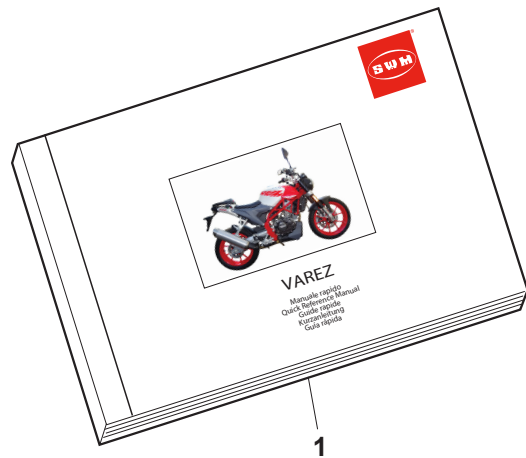
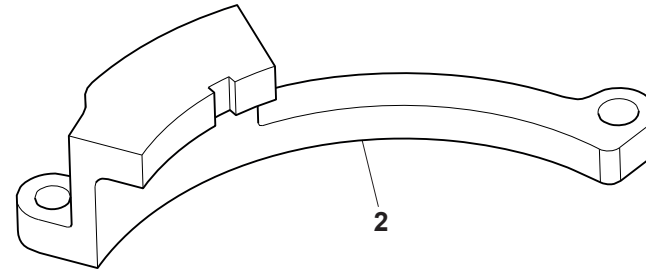
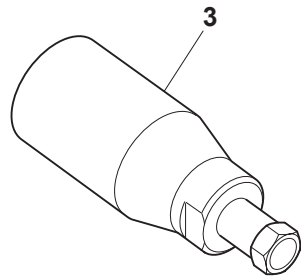



**ATTREZZI DI ASSISTENZA, MANUALI E DOTAZIONI - SERVICE TOOLS, MANUALS AND EQUIPMENT
 OUTILS D'ASSISTANCE, MANUELS ET EQUIPEMENT - HILFAUSRUSTUNG, HANDBUCH UND DOTIERUNG
 HERRAMIENTAS DE ASISTENCIA, MANUALES Y EQUIPAMIENTO**

Note Notes Marke Notas	Pos. No. Index Pos.	N. Cod. Code No. Nr. Code Code Nr N. Cod.	Q.tà Q.ty M.ge C.ad	DENOMINAZIONE	NAME	DESIGNATION	BESHREIBUNG	DENOMINACION
	1	A000P02797	1	QUICK MANUAL	QUICK MANUAL	GUIDE RAPIDE	QUICK MANUAL	QUICK MANUAL
	2	M000P02026	1	ATTREZZO FERMO VOLANO PMS	TDC FLYWHEEL RETAINING TOOL	OUTIL D'ARRET VOLANT AU P.M.H.	KLEMMWERKZEUG SICHERUNGS SCHWUNGRAD AM OT	HERRAMIENTA DE RETENCION VOLANTE EN EL PMS
	3	M000P02025	1	ESTRATTORE VOLANO	FLYWHEEL PULLER	EXTRACTEUR VOLANT	ABZIEHER SCHWUNGRAD	EXTRACTOR VOLANTE
	4	F000A03032	1	KIT SERRATURE	LOCK KIT	KIT SERRURES	SATZ SCHLÖSSER	KIT CERRADURAS
	5	F000P03483	1	CHIAVE GREZZA	KEY BLANK	CLÉ BRUTE	ROHSCHLÜSSEL	LLAVE EN BRUTO

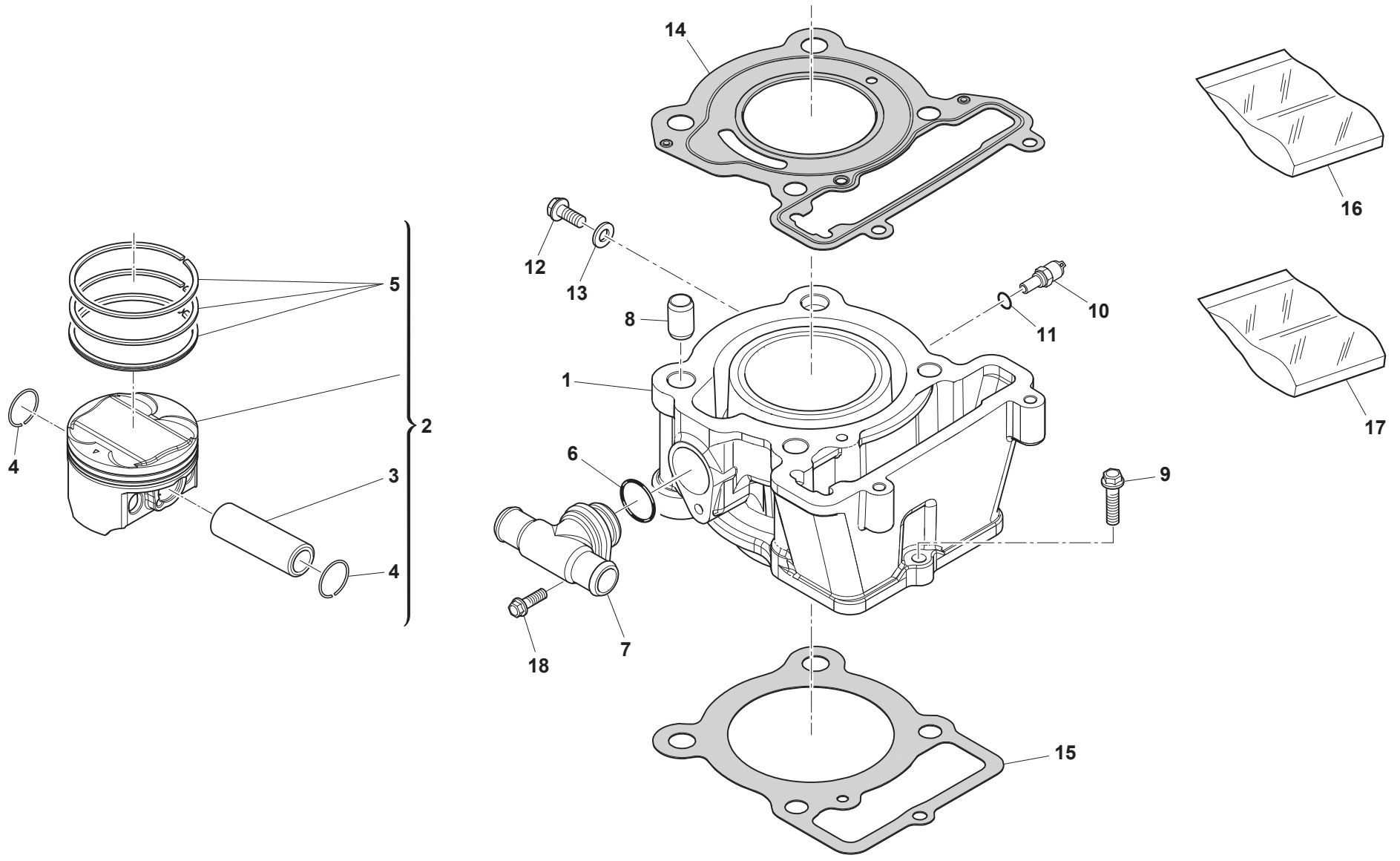

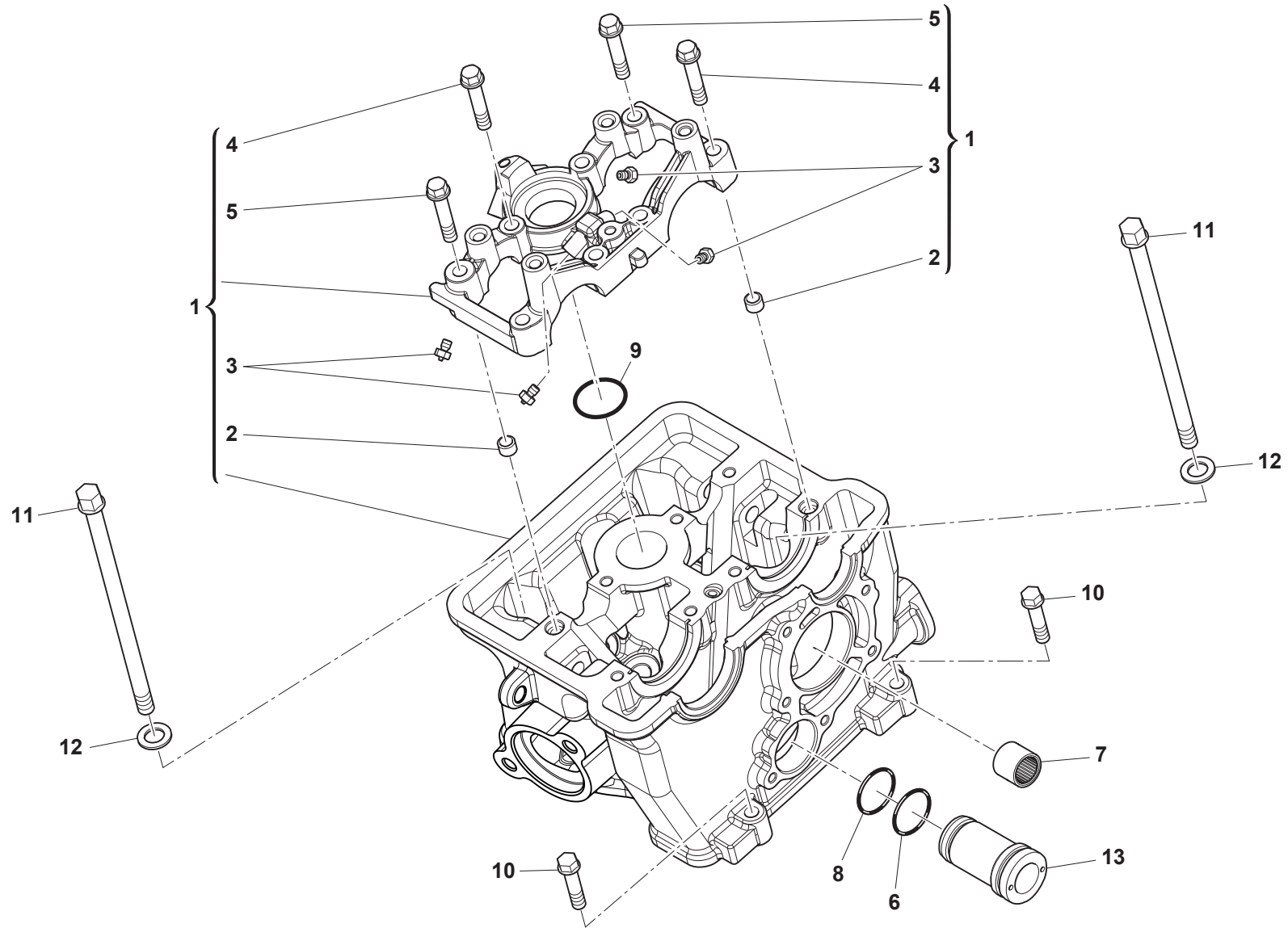

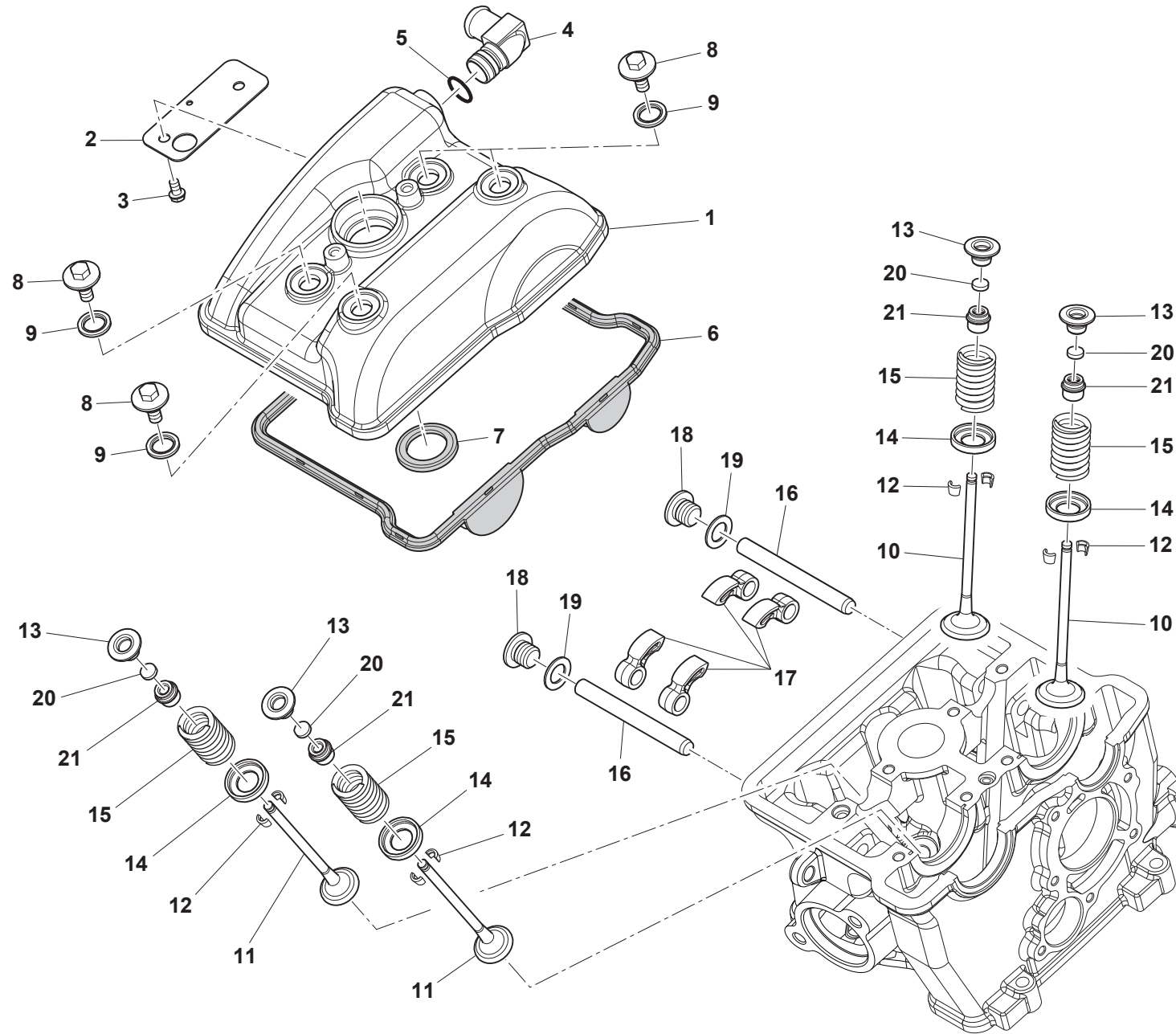

VEDI TAVOLA 3
SEE DRAWING 3
VOIR TABLE 3
SEHEN BILD 3
VER TABLA 3

COPERCHIO VALVOLE - VALVE COVER
COUVERCLE CULASSE - ZYLINDERKOPFDECKEL
TAPA CULATA

Note Notes Marke Notas	Pos. No. Index Pos.	N. Cod. Code No. Nr. Code Code Nr N. Cod.	Q.tà Q.ty Q.te M.ge C.ad	DENOMINAZIONE	NAME	DESIGNATION	BESHREIBUNG	DENOMINACION
	1	22150325	1	COPERCHIO TESTA	HEAD COVER	COUVERCLE CULASSE	ZYLINDERKOPFDECKEL	TAPA CULATA
	2	73131648	1	PIASTRA BLOW BY	BLOW-BY PLATE	PLAQUE BLOW-BY	BLOW-BY PLATTE	PLACA BLOW-BY
	3	72012186	2	VITE TE M5x10	SCREW TE M5x10	VIS TE M5x10	SCHRAUBE TE M5x10	TORNILLO TC M6x12
	4	8000A7039	1	RACCORDO SFIATO	BREATHER PIPE FITTING	RACCORD RENIFLARD	ENTLÜFTUNGSANSCHLUSS	RACOR RESPIRADERO
	5	72150213	1	ANELLO OR	O-RING	JOINT TORIQUE	O-RING	JUNTA TORICA
	6	72150230	1	GUARNIZIONE COPERCHIO TESTA	HEAD COVER GASKET	JOINT COUVERCLE CULASSE	DICHTUNG ZYLINDERKOPFDECKEL	JUNTA TAPA CULATA
	7	72150233	1	GOMMINO	RUBBER RING	JOINT EN CAOUTCHOUC	GUMMISCHEIBE	GOMA
	8	72012182	4	VITE	BOLT	VIS	SCHRAUBE	TORNILLO
	9	73012547	4	RONDELLA GM2000	GM2000 WASHER	RONDELLE GM2000	UNTERLEGSCHIEBE GM2000	ARANDELA
	10	22020098	2	VALVOLA DI ASPIRAZIONE	INTAKE VALVE	SOUPAPE D'ADMISSION	EINLASSVENTIL	VÁLVULA DE ADMISIÓN
	11	22020099	2	VALVOLA DI SCARICO	EXHAUST VALVE	SOUPAPE D'ÉCHAPPEMENT	AUSLASSVENTIL	VÁLVULA DE ESCAPE
	12	22040010	8	SEMICONO	COLLET	DEMI-CONE	KEGELHÄLFTE	SEMICONO
	13	22030022	4	SCODELLINO	RETAINER	RONDELLE A RESSORT	FEDERTELLER	ASIENTO
	14	22030023	4	PIATTELLO	PLATE	PLATEAU	FEDERTELLER	PLATO
	15	M000P04281	4	MOLLA PER VALVOLA	VALVE SPRING	RESSORT POUR SOUPAPE	FEDER FÜR VENTIL	MUELLE PARA VALVULA
	16	22070033	2	PERNO	PIN	AXE	BOLZEN	EJE
	17	22050045	4	BILANCIERE	ROCKER ARM	CULBUTEUR	UMLENK-HEBEL	BALANCÍN
	18	72012177	2	TAPPO	PLUG	BOUCHON	STOPFEN	TAPON
	19	72040667	2	ROSETTA	WASHER	RONDELLE	UNTERLEGSCHIEBE	ARANDELA
	20	22020100	4	PASTIGLIA VALVOLA 1,2 mm - 2,4 mm	1,2 mm - 2,4 mm PAD, VALVE ADJUSTING	PASTILLE REGLAGE CULBETEUR 1,2 mm - 2,4 mm	VENTILKAEPPCHEN 1,2 mm - 2,4 mm	REGISTRO BALANCIN 1,2 mm - 2,4 mm
	21	72110237	4	TENUTA VALVOLE	VALVE SEALING	D'ETANCHEITE SOUPAPES	VENTILDICHTUNGS	ESTANQUEIDAD VALVULAS Ø5

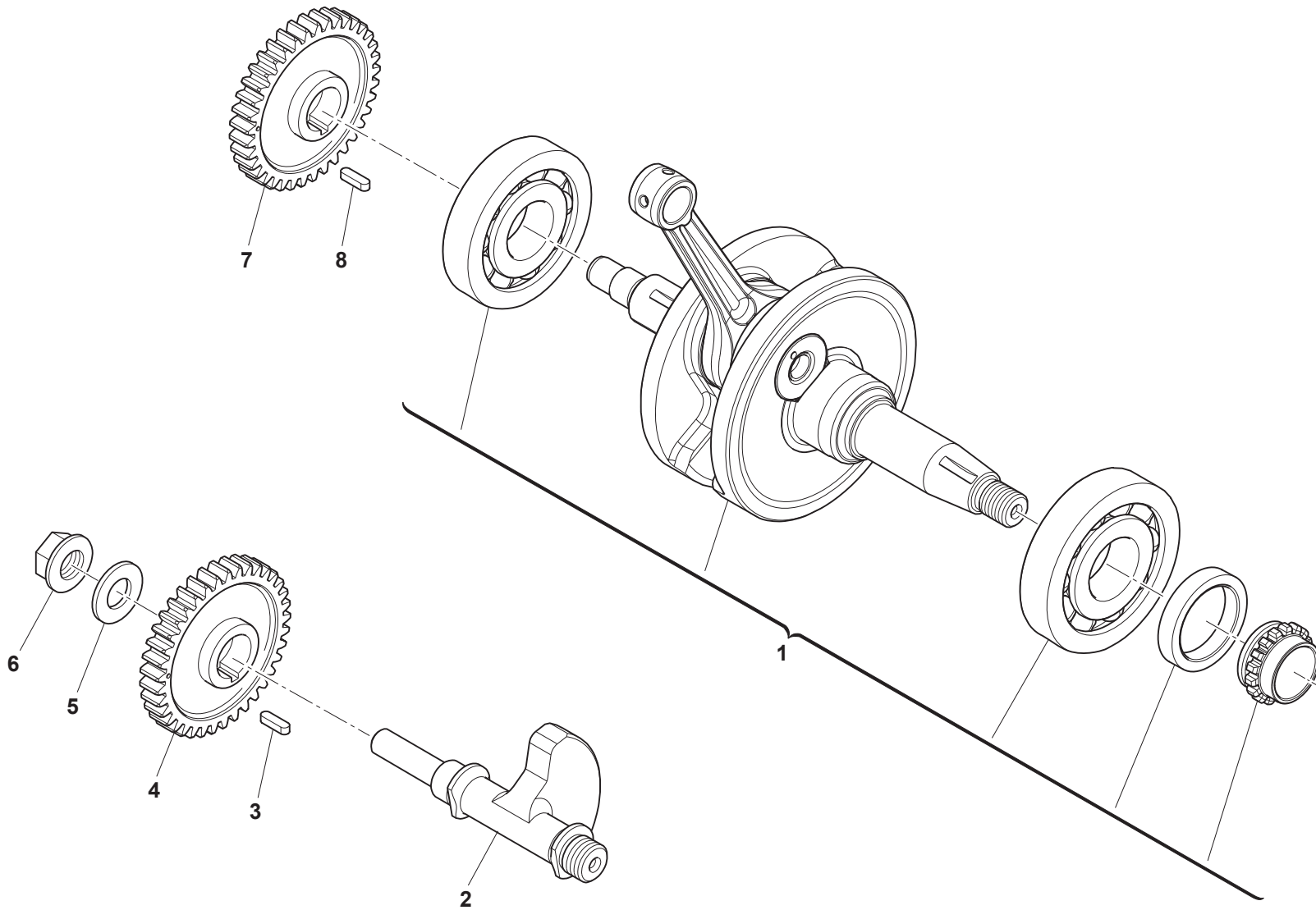

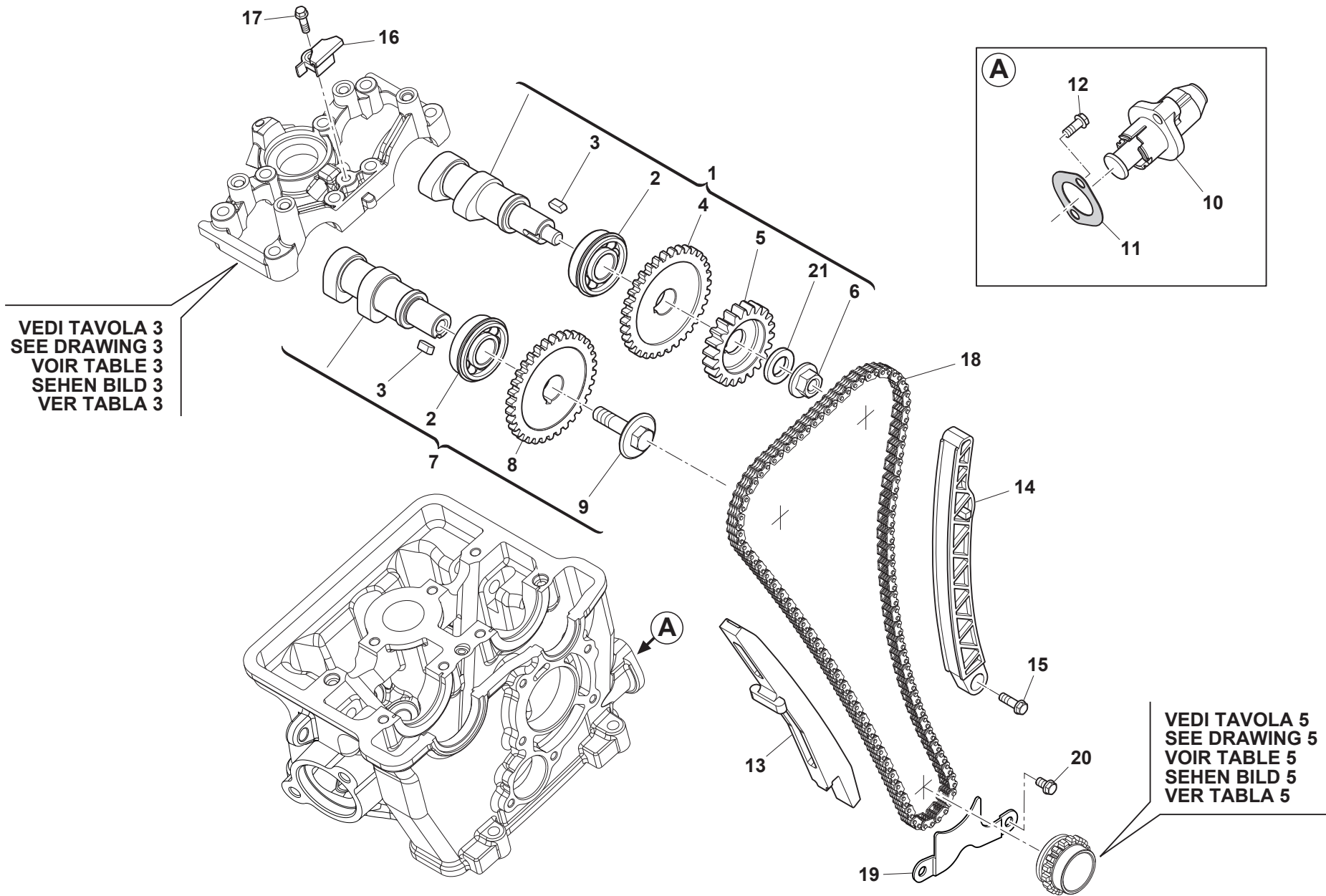

Note Notes Notes Marke Notas	Pos. No. Index Pos.	N. Cod. Code No. Nr. Code Code Nr N. Cod.	Q.tà Q.ty Q.te M.ge C.ad	DENOMINAZIONE	NAME	DESIGNATION	BESHREIBUNG	DENOMINACION
	1	76220003	1	ALBERO A CAMME ASPIRAZIONE	INTAKE CAMSHAFT	ARBRE A CAMES ADMISSION	NOCKENWELLE EINLASS	ARBOL DE LEVAS ADMISIÓN
	2	22190019	2	CUSCINETTO RADIALE 6202NR	RADIAL BEARING 6202NR	ROULEMENT RADIAL 6202NR	RADIALLAGER 6202NR	COJINETE RADIAL 6202NR
	3	21210012	2	LINGUETTA	TAB	LANGUETTE	FEDERKEIL	LENGÜETA
	4	15170125	1	INGRANAGGIO CONDOTTO	DRIVEN GEAR	ENGRENAGE CONDUIT	ANGETRIEBENES ZAHNRAD	ENGRANAJE CONDUCCIDO
	5	17010012	1	INGRANAGGIO POMPA	PUMP GEAR	ENGRENAGE POMPE	PUMPENZAHRAD	ENGRANAJE BOMBA
	6	72020544	1	DADO FLANGIATO M8	FLANGED NUT M8	ECROU BRIDE M8	FLANSCHMUTTER M8	TUERCA CON BRIDA M8
	7	76220004	1	ALBERO A CAMME SCARICO	EXHAUST CAMSHAFT	ARBRE A CAMES ECHAPPEMENT	NOCKENWELLE AUSLASS	ARBOL DE LEVAS ESCAPE
	8	15170126	1	INGRANAGGIO CONDOTTO	DRIVEN GEAR	ENGRENAGE CONDUIT	ANGETRIEBENES ZAHNRAD	ENGRANAJE CONDUCCIDO
	9	72012176	1	VITE SPECIALE M8x30	M8x30 SPECIAL BOLT	VIS SPÉCIAUX M8x30	SPEZIALSCHRAUBE M8x30	TORNILLO ESPECIAL M8x30
	10	8000A6950	1	TENDICATENA COMPLETO	COMPLETE CHAIN TENSIONER	TENDEUR DE CHAÎNE COMPLET	KETTENSANNER KOMPLETT	SENSOR DE CADENA COMPLETO
	11	8000A6954	1	GUARNIZIONE	GASKET	JOINT	DICHTUNG	JUNTA
	12	72010163	2	VITE TEF M6x25	FLANGED EXAGON HEAD SCREW M6x25	BOULON DE BRIDE M6x25	FLANSCHENSCHRAUBE M6x25	TORNILLO DE REBORDE M6x25
	13	73012518	1	PATTINO FISSO	FIXED SLIDER	PATIN FIXE	FESTE KETTENSANNERAUFLAGE	PATÍN FIJO
	14	73012517	1	PATTINO MOBILE	MOVING SLIDER	PATIN MOBILE	BEWEGLICHE KETTENSANNERAUFLAGE	PATÍN MÓVIL
	15	72012183	1	VITE	BOLT	VIS	SCHRAUBE	TORNILLO
	16	73012519	1	PATTINO	SLIDER	PATIN	SPANNERAUFLAGE	PATÍN
	17	72010157	1	VITE TEF M6x16	FLANGED EXAGON HEAD SCREW M6x16	BOULON DE BRIDE M6x16	FLANSCHENSCHRAUBE M6x16	TORNILLO DE REBORDE M6x16
	18	15160047	1	CATENA DISTRIBUZIONE (120 MAGLIE)	TIMING CHAIN (120 LINKS)	CHAÎNE DE DISTRIBUTION (120 MAILLONS)	VENTILSTEUERKETTE (120 GLIEDER)	CADENA DISTRIBUCION (120 ESLABONES)
	19	73131547	1	PIASTRA GUIDACATENA DISTRIBUZIONE	TIMING CHAIN GUIDE PLATE	PLAQUE GUIDE DE CHAÎNE DISTRIBUTION	PLATTE KETTENFÜHRUNG VENTILSTEUER	PLACA GUÍA CADENA DISTRIBUCION
	20	72010157	1	VITE TEF M6x16	FLANGED EXAGON HEAD SCREW M6x16	BOULON DE BRIDE M6x16	FLANSCHENSCHRAUBE M6x16	TORNILLO DE REBORDE M6x16
	21	72040431	1	ROSETTA PIANA IN ACCIAIO 8x20x2	IRON FLAT WASHER 8x20x2	RONDELLE PLATE 8x20x2	FLACHE UNTERLEGSCHIEBE 8x20x2	ARANDELA PLANA 8x20x2

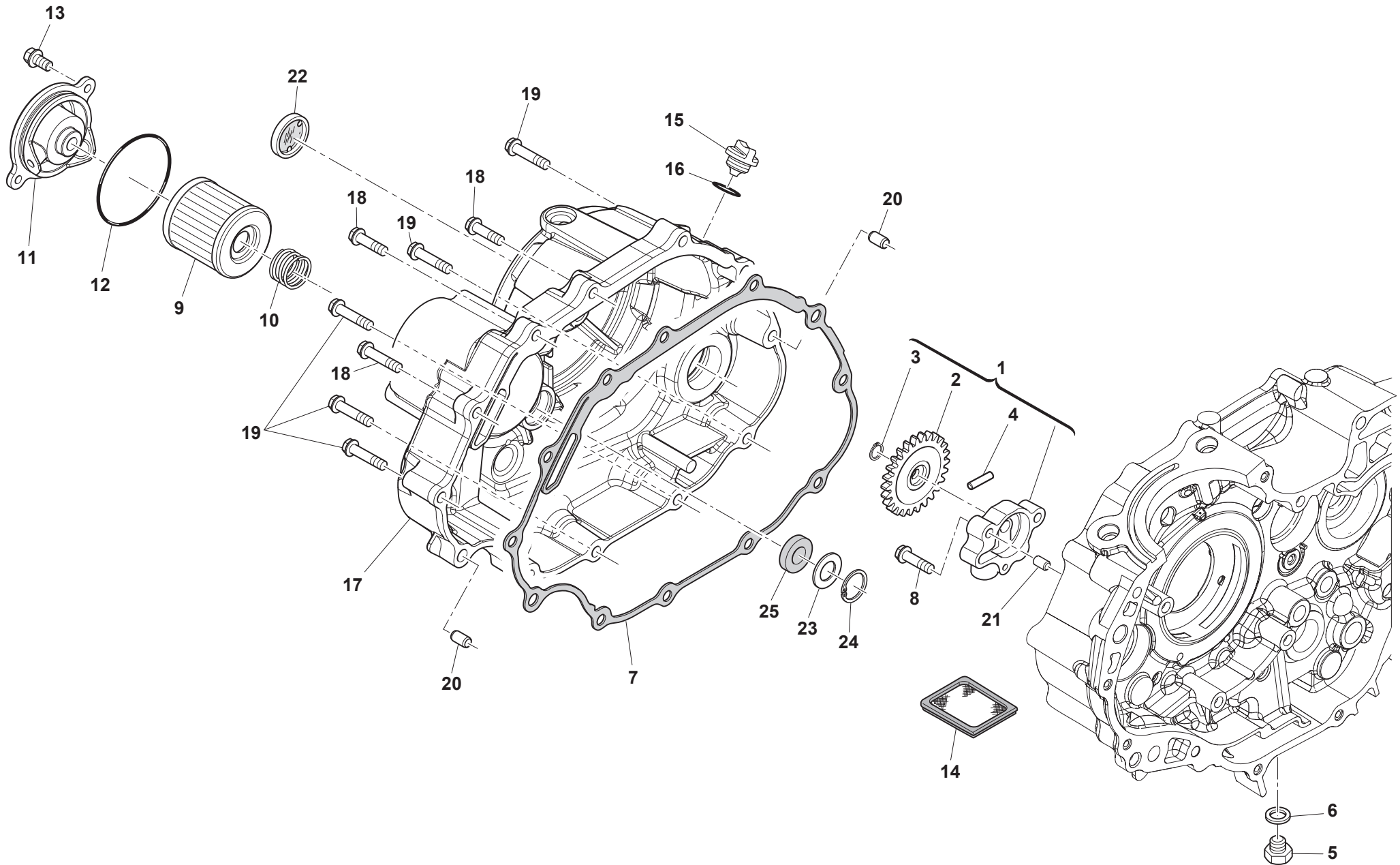

Note Notes Notes Marke Notas	Pos. No. N. Index Pos.	N. Cod. Code No. Nr. Code Code Nr N. Cod.	Q.tà Q.ty Q.te M.ge C.ad	DENOMINAZIONE	NAME	DESIGNATION	BESHREIBUNG	DENOMINACION
	1	20010078	1	POMPA OLIO COMPLETA	COMPLETE OIL PUMP	POMPE A HUILE COMPLETE	ÖLPUMPE KOMPLETT	BOMBA ACEITE COMPLETA
	2	20080022	1	INGRANAGGIO POMPA OLIO	OIL PUMP GEAR	ENGRENAGE POMPE	PUMPENZAHNRAD	ENGRANAJE BOMBA
	3	20080024	1	ANELLO DI FERMO	RETAINING RING	BAGUE D'ARRET	SICHERUNGSRING	ANILLO DE RETENCION
	4	20080023	1	RULLINO Ø3x16	RØ3x16 OLLER	AIGUILLE Ø3x16	ROLLE Ø3x16	RODILLO Ø3x16
	5	72012089	1	TAPPO SCARICO OLIO	OIL DRAIN PLUG	BOUCHON VIDANGE D'HUILE	OLABLASSSCHRAUBE	TAPON VACIADO ACEITE
	6	72040159	1	ROSETTA	WASHER	RONDELLE	UNTERLEGSCHEIBE	ARANDELA
	7	72130623	1	GUARNIZIONE COPERCHIO FRIZIONE	GASKET	JOINT	DICHTUNG	JUNTA
	8	72010168	2	VITE TEF M6x30	FLANGED EXAGON HEAD SCREW M6x30	BOULON DE BRIDE M6x30	SCHRAUBE M6x30	TORNILLO M6x30
	9	8000B0593	1	FILTRO OLIO A CARTUCCIA	OIL CARTRIDGE FILTER	FILTRE À HUILE À CARTOUCHE	PATRONEN-ÖLFILTER	FILTRO ACEITE DE CARTUCHO
	10	72120166	1	MOLLA PREMI FILTRO-CARTUCCIA	FILTER/CARTRIDGE PRESSING SPRING	RESSORT PRESSE FILTRE-CARTOUCHE	DRUCKFEDER FILTER-PATRONE	MUELLE PRENSA FILTRO-CARTUCHO
	11	14090088	1	COPERCHIO FILTRO OLIO	OIL FILTER COVER	COUVERCLE	DECKEL	TAPA
	12	72150237	1	ANELLO OR	O-RING	JOINT TORIQUE	O-RING	JUNTA TORICA
	13	72010157	2	VITE M6x16	SCREW M6x16	VIS M6x16	SCHRAUBE M6x16	TORNILLO M6x16
	14	11060002	1	FILTRO A RETE	MESH FILTER	FILTRE À GRILLE	NETZFILTER	FILTRO DE RED
	15	14060064	1	TAPPO CARICO OLIO	OIL FILLER PLUG	BOUCHON DE REMPLISSAGE HUILE	ÖLEINFÜLLSCHRAUBE	TAPON LLENADO ACEITE
	16	72150018	1	ANELLO OR	O-RING	JOINT TORIQUE	O-RING	JUNTA TORICA
	17	14011082	1	COPERCHIO SINISTRO	LEFT COVER	CACHE GAUCHE	LINKER DECKEL	TAPA IZQUIERDA
	18	72010387	3	VITE TEF M6x28	FLANGED EXAGON HEAD SCREW M6x28	BOULON DE BRIDE M6x28	FLANSCHENSCHRAUBE	TORNILLO DE REBORDE M6x28
	19	72010389	9	VITE TEF M6x40	FLANGED EXAGON HEAD SCREW M6x40	BOULON DE BRIDE M6x40	M6x28 SCHRAUBE M6x40	TORNILLO M6x40
	20	72060012	2	BUSSOLA	BUSHING	DOUILLE	BUCHSE	CASQUILLO
	21	72060013	2	BUSSOLA	BUSHING	DOUILLE	BUCHSE	CASQUILLO
	22	800073529	1	OBLÒ PER LIVELLO OLIO	OIL LEVEL INSPECTION SIGHT GLASS	HUBLOT DE CONTRÔLE NIVEAU D'HUILE	SCHAUGLAS FÜR ÖLSTAND	MIRILLA PARA NIVEL ACEITE
	23	72040677	1	ROSETTA	WASHER	RONDELLE	UNTERLEGSCHEIBE	ARANDELA
	24	72080073	1	ANELLO ELASTICO	CIRCLIP	CIRCLIP	SPRENGRING	ANILLO ELASTICO
	25	8A0028855	1	ANELLO DI TENUTA Ø12xØ18x5	Ø12xØ18x5 SEALING RING	BAGUE D'ETANCHEITE Ø12xØ18x5	DICHTUNGSRING Ø12xØ18x5	ANILLO DE ESTANQUEIDAD Ø12xØ18x5

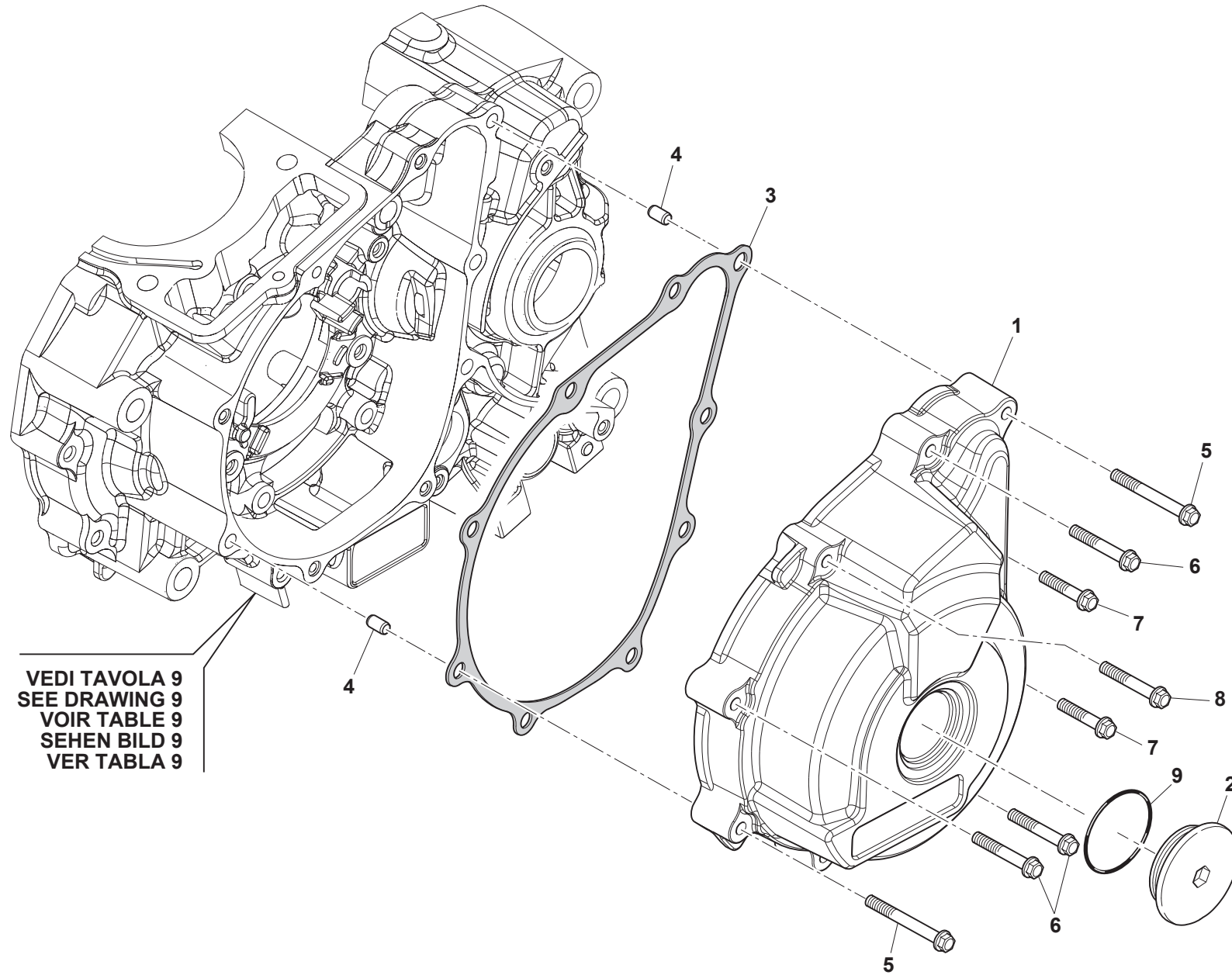

VEDI TAVOLA 9
SEE DRAWING 9
VOIR TABLE 9
SEHEN BILD 9
VER TABLA 9

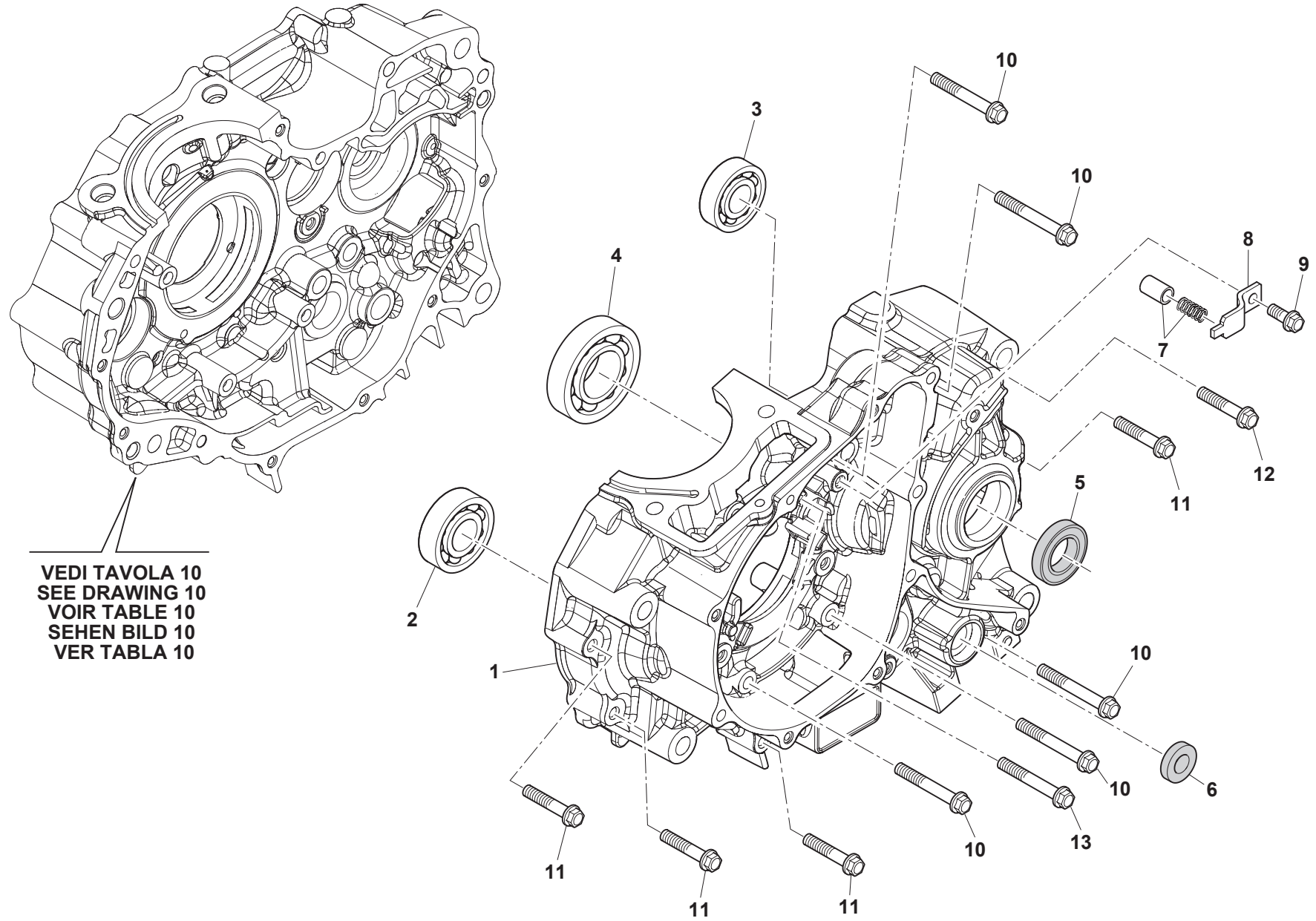

VEDI TAVOLA 10
SEE DRAWING 10
VOIR TABLE 10
SEHEN BILD 10
VER TABLA 10

**SEMICARTER SINISTRO - LEFT HALF CRANKCASE
CARTER GAUCHE - GEHAUSEDECKEL LINKS
BANCADA IZQUIERDA**

Note Notes Notes Marke Notas	Pos. No. N. Index Pos.	N. Cod. Code No. Nr. Code Code Nr N. Cod.	Q.tà Q.ty Q.te M.ge C.ad	DENOMINAZIONE	NAME	DESIGNATION	BESHREIBUNG	DENOMINACION
	1	11010698	1	CARTER SINISTRO	LEFT CRANKCASE	CARTER G.	DECKEL R.	CÁRTER DER.
	2	70090011	1	CUSCINETTO ALBERO PRIMARIO Ø17xØ40x12	Ø17xØ40x12 INPUT SHAFT BEARING	ROULEMENT ARBRE PRIMAIRE Ø17xØ40x12	HAUPTANTRIEBSWELLE LAGER Ø17xØ40x12	COJINETE ARBOL PRIMARIO Ø17xØ40x12
	3	70090137	1	CUSCINETTO ALBERO SECONDARIO Ø20Ø47x14	Ø20Ø47x14 OUTPUT SHAFT BEARING	ROULEMENT ARBRE SECONDAIRE Ø20Ø47x14	VORGELEGEWELLE LAGER Ø20Ø47x14	COJINETE ARBOL SECUNDARIO Ø20Ø47x14
	4	70090005	1	CUSCINETTO ALBERO PRIMARIO Ø12xØ32x10	Ø12xØ32x10 INPUT SHAFT BEARING	ROULEMENT ARBRE PRIMAIRE Ø12xØ32x10	HAUPTANTRIEBSWELLE LAGER Ø12xØ32x10	COJINETE ARBOL PRIMARIO Ø12xØ32x10
	5	72110011	1	ANELLO DI TENUTA Ø20xØ34x7	Ø20xØ34x7 SEALING RING	BAGUE D'ETANCHEITE Ø20xØ34x7	DICHTUNGSRING Ø20xØ34x7	ANILLO DE ESTANQUEIDAD Ø20xØ34x7
	6	72110012	1	ANELLO DI TENUTA Ø14x22x5	SEALING RING Ø14x22x5	BAGUE D'ETANCHEITE Ø14x22x5	DICHTUNGSRING Ø14x22x5	ANILLO DE ESTANQUEIDAD Ø14x22x5
	7	11080005	1	PUNTALE + MOLLA	PUSH ROD + SPRING	EMBOUT + RESSORT	STIFT + FEDER	PUNTA + MUELLE
	8	73131647	1	PIASTRA PUNTALE	PUSH ROD PLATE	PLAQUE EMBOUT	PLATTE STIFT	PLACA PUNTA
	9	72010157	1	VITE M6x16	SCREW M6x16	VIS M6x16	SCHRAUBE M6x16	TORNILLO M6x16
	10	72010393	5	VITE TEF M6x70	FLANGED EXAGON HEAD SCREW M6x70	BOULON DE BRIDE M6x70	SCHRAUBE M6x70	TORNILLO M6x70
	11	72010389	6	VITE TEF M6x40	FLANGED EXAGON HEAD SCREW M6x40	BOULON DE BRIDE M6x40	SCHRAUBE M6x40	TORNILLO M6x40
	12	72010169	1	VITE TEF M6x35	FLANGED EXAGON HEAD SCREW M6x35	BOULON DE BRIDE M6x35	FLANSCHENSCHRAUBE M6x35	TORNILLO DE REBORDE M6x35
	13	72010392	1	VITE TEF M6x65	FLANGED EXAGON HEAD SCREW M6x65	BOULON DE BRIDE M6x65	SCHRAUBE M6x65	TORNILLO M6x65

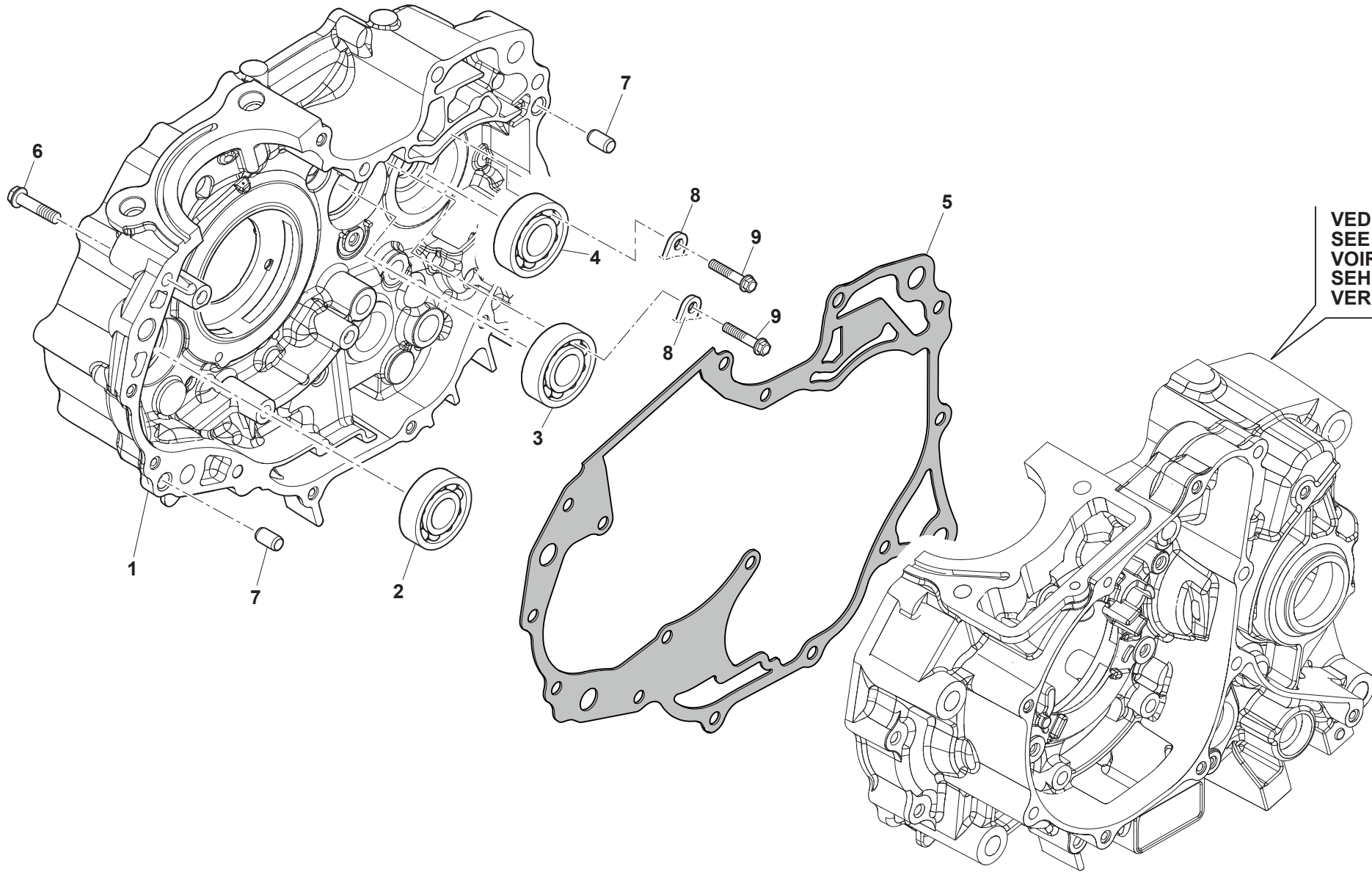

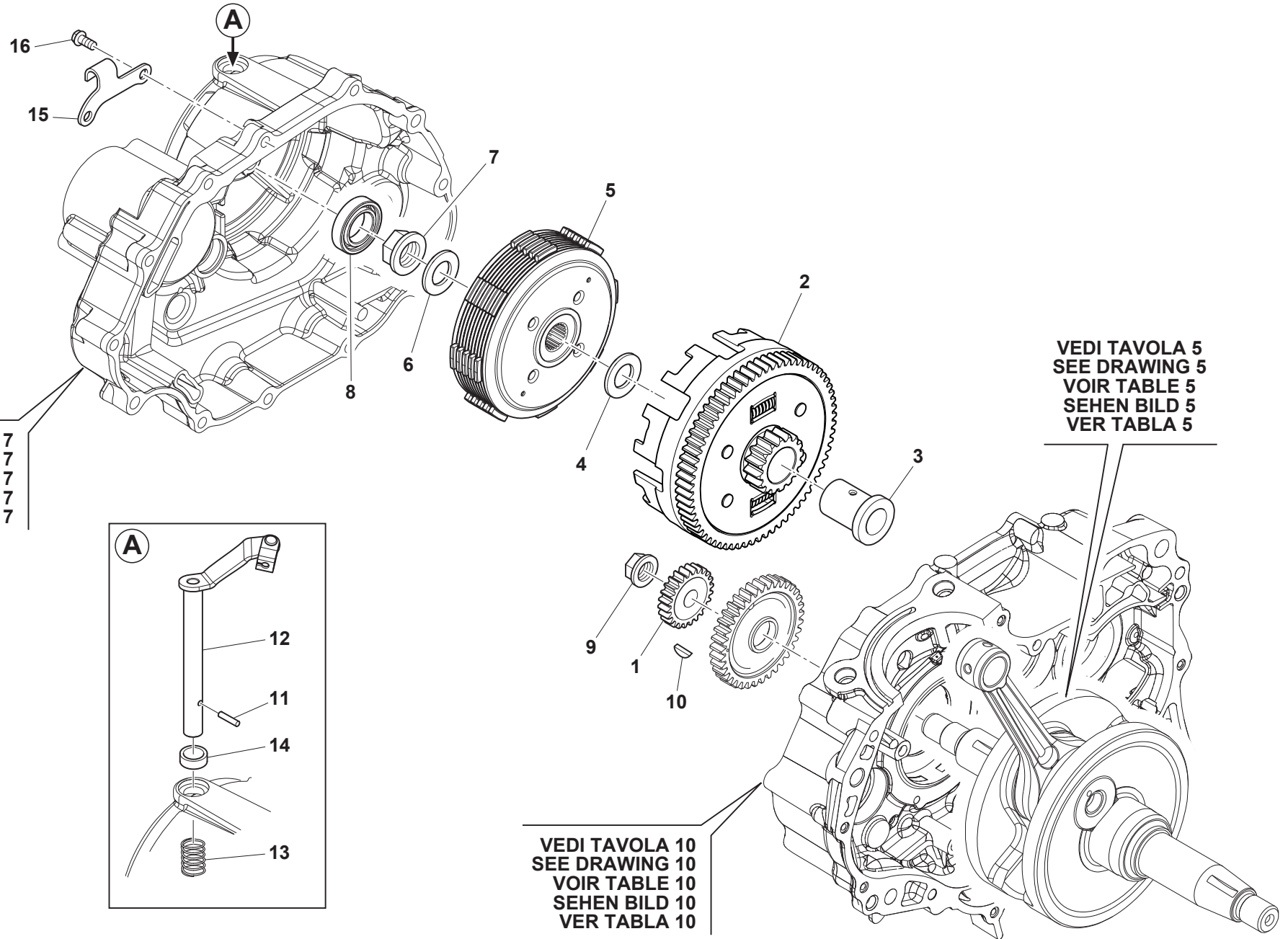

VEDI TAVOLA 7
SEE DRAWING 7
VOIR TABLE 7
SEHEN BILD 7
VER TABLA 7

VEDI TAVOLA 5
SEE DRAWING 5
VOIR TABLE 5
SEHEN BILD 5
VER TABLA 5

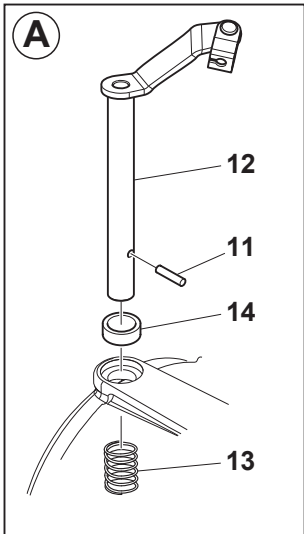

VEDI TAVOLA 10
SEE DRAWING 10
VOIR TABLE 10
SEHEN BILD 10
VER TABLA 10

**FRIZIONE - CLUTCH
EMBAYAGE - KUPPLUNG
EMBRAGUE**

Note Notes Notes Marke Notas	Pos. No. Index Pos.	N. Cod. Code No. Nr. Code Code Nr N. Cod.	Q.tà Q.ty Q.te M.ge C.ad	DENOMINAZIONE	NAME	DESIGNATION	BESHREIBUNG	DENOMINACION
	1	24020060	1	PIGNONE PRIMARIO	INPUT SPROCKET	PIGNON PRIMAIRE	RITZELWELLE	PINON PRIMARIO
	2	24070322	1	INGRANAGGIO CONDOTTO	DRIVEN GEAR	ENGRENAGE CONDUIT	ANGETRIEBENES ZAHNRAD	ENGRANAJE CONDUCTIDO
	3	24070155	1	BUSSOLA	BUSHING	DOUILLE	BUCHSE	CASQUILLO
	4	24070312	1	ROSETTA	WASHER	RONDELLE	UNTERLEGSCHEIBE	ARANDELA
	5	24070248	1	GRUPPO DISCHI FRIZIONE	CLUTCH PLATE ASSY	ENSEMBLE DISQUES EMBRAYAGE	KUPPLUNGSSCHEIBENGRUPPE	GRUPO DISCOS EMBRAGUE
	6	24070221	1	ROSETTA 14,2x29x2,8	WASHER 14,2x29x2,8	RONDELLE 14,2x29x2,8	UNTERLEGSCHEIBE 14,2x29x2,8	ARANDELA 14,2x29x2,8
	7	24070221	1	DADO FLANGIATO M14x1	FLANGED NUT M14x1	ECROU BRIDE M14x1	FLANSMUTTER M14x1	TUERCA CON BRIDA M14x1
	8	24070223	1	CUSCINETTO 6003	BEARING 6003	ROULEMENT 6003	LAGER 6003	COJINETE 6003
	9	72020546	1	DADO FLANGIATO M14x1 SINISTRO	LEFT FLANGED NUT M14x1	ECROU BRIDE M14x1 GAUCHE	FLANSMUTTER M14x1 LINKS	TUERCA CON BRIDA M14x1 IZQUIERDO
	10	21210014	1	CHIAVETTA 4x4	4x4 WOODRUFF KEY	CLÉ 4x4	FEDERKEIL 4x4	MEMORIA 4x4
	11	72060031	1	SPINA	DOWEL	GOUPILLE	STIFT	CLAVIJA
	12	24030070	1	LEVA COMANDO FRIZIONE	CLUTCH CONTROL LEVER	LEVIER DE COM. EMBRAYAGE	KUPPLUNGSHABEL	PALANCA MANDO EMBRAGUE
	13	72120103	1	MOLLA	SPRING	RESSORT	FEDER	MUELLE
	14	72110024	1	ANELLO DI TENUTA Ø12xØ18x5	Ø12xØ18x5 SEALING RING	BAGUE D'ETANCHEITE Ø12xØ18x5	DICHTUNGSRING Ø12xØ18x5	ANILLO DE ESTANQUEIDAD Ø12xØ18x5
	15	73131855	1	PIASTRINA	PLATE	PLAQUETTE	PLÄTTCHEN	PLACA
	16	72010387	2	VITE TEF M6x28	FLANGED EXAGON HEAD SCREW M6x28	BOULON DE BRIDE M6x28	FLANSCHENSCHRAUBE M6x28	TORNILLO DE REBORDE M6x28

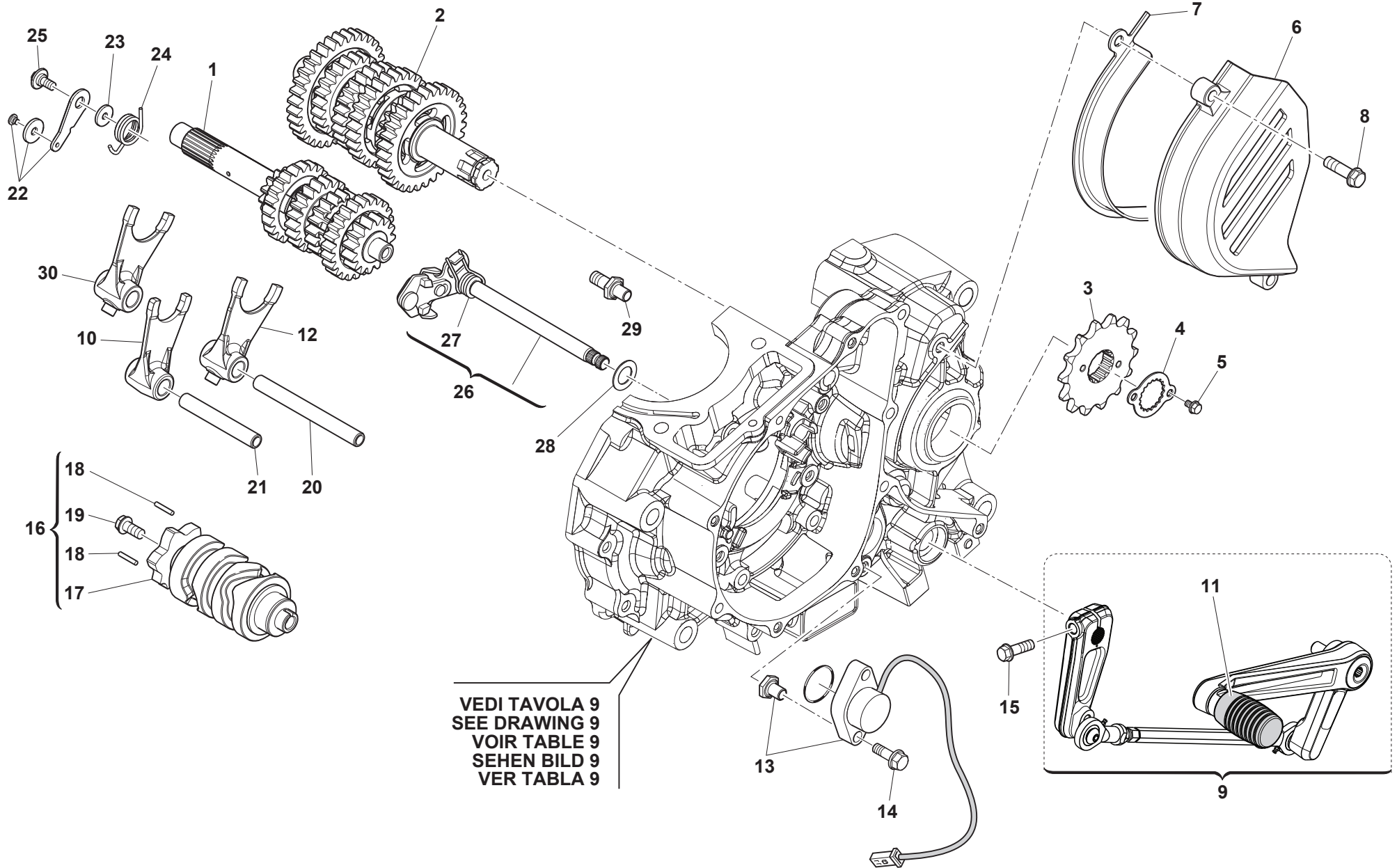

VEDI TAVOLA 9
SEE DRAWING 9
VOIR TABLE 9
SEHEN BILD 9
VER TABLA 9

Note Notes Marke Notas	Pos. No. N. Index Pos.	N. Cod. Code No. Nr. Code Code Nr N. Cod.	Q.tà Q.ty Q.te M.ge C.ad	DENOMINAZIONE	NAME	DESIGNATION	BESHREIBUNG	DENOMINACION
	1	15020130	1	ASSIEME ALBERO PRIMARIO	INPUT SHAFT ASSY	ARBRE PRIMAIRE COMPL.	ZUSAMMENBAU HAUPTANTRIEBSWELLE	CONJUNTO ARBOL PRIMARIO
	2	15030170	1	ASSIEME ALBERO SECONDARIO	OUTPUT SHAFT ASSY	ARBRE SECONDAIRE COMPL.	ZUSAMMENBAU VORGELEGEWELLE	CONJUNTO ARBOL SECONDARIO
	3	15170128	1	PIGNONE USCITA CAMBIO Z=14	TRANSMISSION SPROCKET T=14	PIGNON SORTIE BOÎTE DE VITESSES Z=14	GETRIEBE-AUSGANGSRITZEL Z=14	PINON SALIDA CAMBIO Z=14
	4	73130522	1	PIASTRA FISSAGGIO PIGNONE	PINION FIXING BRACKET	PLAQUE PIGNON	RITZELPLATTE	PLACA PINON
	5	72010089	2	VITE M6x10	M6x10 BOLT	VIS M6x10	SCHRAUBE M6x10	TORNILLO M6x10
	6	M000P00335	1	COPERCHIO PIGNONE CATENA	CHAIN SPROCKET COVER	COUVERCLE PIGNON CHAÎNE	DECKEL KETTENRITZEL	TAPA PINON CADENA
	7	M000P00336	1	PIASTRINA	PLATE	PLAQUETTE	PLÄTTCHEN	PLACA
	8	Z00062728	2	VITE TEF M6x20	FLANGED EXAGON HEAD SCREW M6x20	BOULON DE BRIDE M6x20	SCHRAUBE M6x20	TORNILLO M6x20
	9	F000A02818	1	ASS. LEVA COMANDO CAMBIO	GEAR CONTROL LEVER ASSY	LEVIER DE COM. BOÎTE DE VITESSES COMPL.	ZSB. SCHALTABEL	CONJ. PALANCA MANDO CAMBIO
	10	15140055	1	FORCELLA INGRANAGGIO 5ª E 6ª VELOCITÀ	5TH AND 6TH GEAR FORK	FOURCHE PIGNON 5ÈME ET 6ÈME	GABEL ZAHNRAD 5. UND 6. GANG	HORQUILLA ENGRANAJE 5ª Y 6ª VEL.
	11	F000P03462	1	GOMMINO	RUBBER RING	JOINT EN CAOUTCHOUC	GUMMISCHEIBE	GOMA
	12	15140053	1	FORCELLA INGRANAGGIO 2ª E 3ª VELOCITÀ	2ND AND 3RD GEAR FORK	FOURCHE PIGNON 2ÈME ET 3ÈME	GABEL ZAHNRAD 2. UND 3. GANG	HORQUILLA ENGRANAJE 2ª Y 3ª VEL.
	13	11040208	1	SENSORE FOLLE	NEUTRAL POSITION SWITCH	CAPTEUR POINT MORT	LEERLAUFSSENSOR	SENSOR PUNTO MUERTO
	14	72010163	2	VITE M6x25	BOLT M6x25	VIS M6x25	SCHRAUBE M6x25	TORNILLO M6x25
	15	Z00062728	1	VITE TEF M6x20	FLANGED EXAGON HEAD SCREW M6x20	BOULON DE BRIDE M6x20	SCHRAUBE M6x20	TORNILLO M6x20
	16	76220006	1	ALBERO COMANDO FORCELLE	SELECTOR SHAFT	ARBRE DE COMMANDE FOURCHES	SCHALTGABELWELLE	EJE MANDO HORQUILLAS
	17	15090014	1	TAMBURO SELETTORE MARCE	GEAR SELECTOR DRUM	TAMBOUR SELECTEUR DE VITESSES	SCHALTWALZE	TAMBOR SELECTOR MARCHAS
	18	15050064	2	PERNO	PIN	AXE	BOLZEN	EJE
	19	72010990	1	VITE M6x20	M6x20 BOLT	VIS M6x20	SCHRAUBE M6x20	TORNILLO M6x20
	20	15140041	1	PERNO FORCELLA	FORK PIN	AXE FOURCHE	BOLZEN GABEL	EJE HORQUILLA
	21	15140042	1	PERNO FORCELLA	FORK PIN	AXE FOURCHE	BOLZEN GABEL	EJE HORQUILLA
	22	15080023	1	PIASTRINA DI FERMO SELETTORE	SELECTOR LOCK PLATE	PLAQUETTE D'ARRET SELECTEUR	HALTEPLÄTTCHEN SCHALTWALZE	PLACA DE FIJACION SELECTOR
	23	72040676	1	ROSETTA	WASHER	RONDELLE	UNTERLEGSSCHEIBE	ARANDELA
	24	72120121	1	MOLLA	SPRING	RESSORT	FEDER	MUELLE
	25	72011366	1	VITE	BOLT	VIS	SCHRAUBE	TORNILLO
	26	15070072	1	ASSIEME ALBERO SELETTORE	SELECTOR SHAFT ASSY	ARBRE SELECTEUR COMPL.	ZUSAMMENBAU SCHALTWALZENWELLE	CONJUNTO ARBOL SELECTOR
	27	15130036	1	MOLLA	SPRING	RESSORT	FEDER	MUELLE
	28	72040677	1	ROSETTA	WASHER	RONDELLE	UNTERLEGSSCHEIBE	ARANDELA
	29	72011772	1	PERNO DI FERMO SELETTORE	SELECTOR LOCK PIN	AXE D'ARRET SELECTEUR	BLOCKIERVORRICHTUNG SCHALTWALZE	EJE DE RETENCION SELECTOR
	30	15140054	1	FORCELLA INGRANAGGIO 1ª E 4ª VELOCITÀ	1ST, 4TH GEAR FORK	FOURCHE PIGNON 1ÈRE, 4ÈME	GABEL ZAHNRAD 1. UND 4. GANG	HORQUILLA ENGRANAJE 1ª Y 4ª VEL.

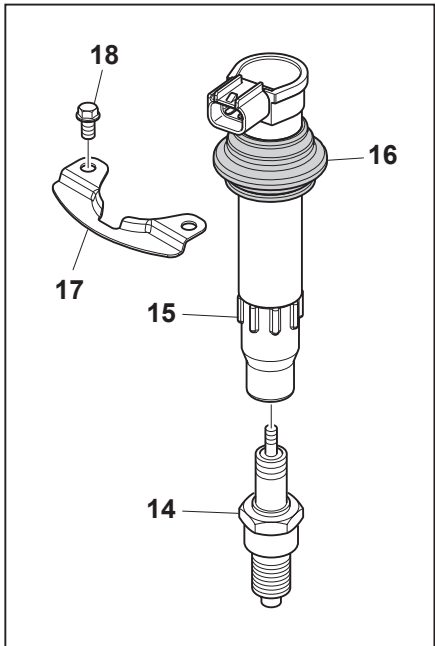
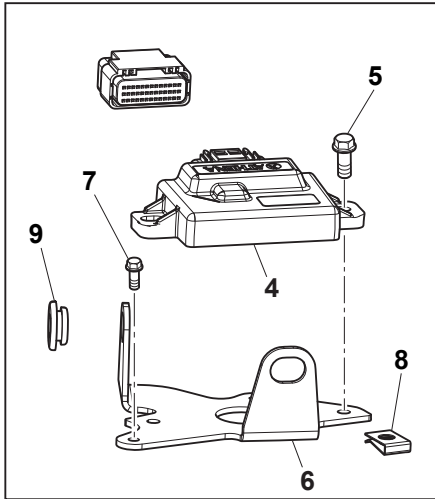

VEDI TAVOLA 14
SEE DRAWING 14
VOIR TABLE 14
SEHEN BILD 14
VER TABLA 14

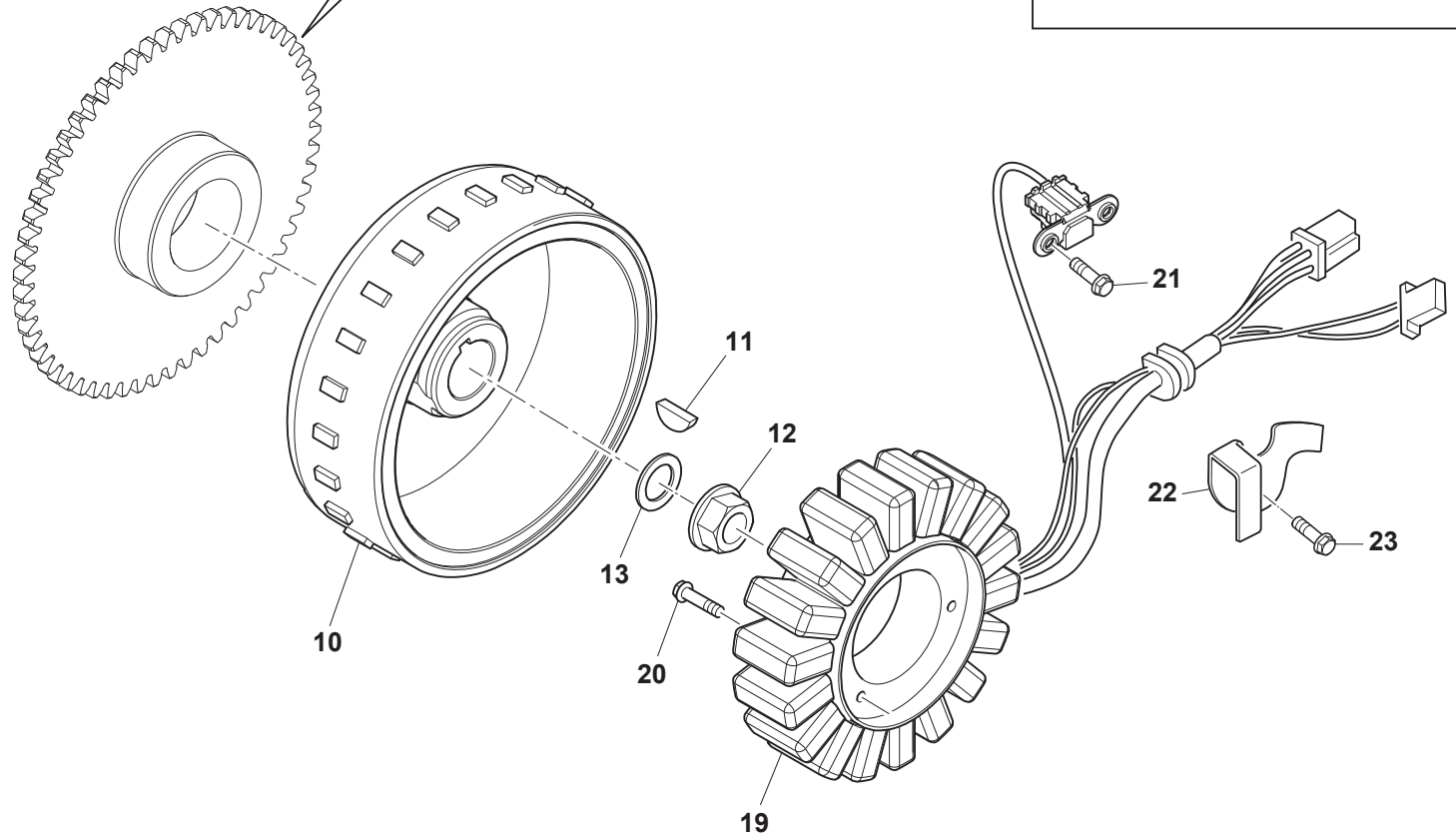
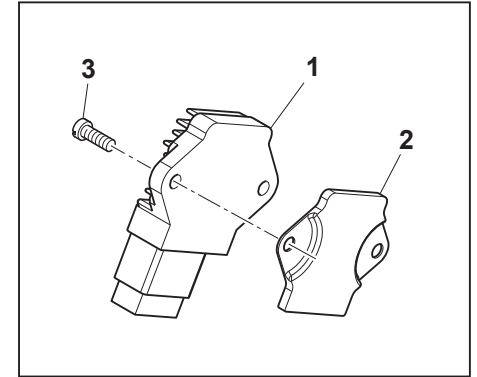

Note Notes Marke Notas	Pos. No. N. Index Pos.	N. Cod. Code No. Nr. Code Code Nr N. Cod.	Q.tà Q.ty Q.te M.ge C.ad	DENOMINAZIONE	NAME	DESIGNATION	BESHREIBUNG	DENOMINACION
	1	8000B0563	1	REGOLATORE DI TENSIONE	VOLTAGE REGULATOR	RÉGULATEUR DE TENSION	SPANNUNGSREGLER	REGULADOR DE TENSIÓN
	2	F000P03685	1	PIASTRINA DISSIPAZIONE CALORE	HEAT DISSIPATION PLATE	PLAQUETTE	PLÄTTCHEN	PLACA
	3	ZH0067545	2	VITE TEF M6x12	FLANGED EXAGON HEAD SCREW M6x12	BOULON DE BRIDE M6x12	FLANSCHENSCHRAUBE M6x12	TORNILLO DE REBORDE M6x12
	4	E000P00814	1	CENTRALINA PROGRAMMATA	PROGRAMMED CONTROL UNIT	BOÏTIER	STEUEREL	CENTRALITA PROGRAMADA
	5	Z00062728	2	VITE M5x16	BOLT M5x16	VIS M5x16	SCHRAUBE M5x16	TORNILLO M5x16
	6	F000P02880	1	PIASTRA ATTACCO CENTRALINA	CONTROL UNIT MOUNTING PLATE	PLAQUE FIXATION BOÏTIER DE COMMANDE	AUFNAHMEPLATTE STEUERGERÄT	PLACA FIJACIÓN CENTRALITA
	7	FA00P03911	3	VITE AUTOFILETTANTETEF M6x14	SELF-TAPP. FLANGED HEX.HD SCREW M6x14	BOULON DE BRIDE TARAUD M6x14	SELBSTSCHN. SECHSKANTSCHR. M. FLANSCH M6x14	TORNILLO AUTOROSCANTE DE REBORDE M6x14
	8	U00046893	2	DADO A GRAFFETTA M6	CLIP NUT M6	ECROU À AGRAFE M6	SICHERUNGSMUTTER M6	TUERCA DE CLIP M6
	9	800041874	2	GOMMINO	RUBBER RING	JOINT EN CAOUTCHOUC	GUMMISCHEIBE	GOMA
	10	31150168	1	ROTORE	ROTOR	ROTOR	ROTOR	ROTOR
	11	21210014	1	CHIAVETTA	WOODRUFF KEY	CLÉ	FEDERKEIL	MEMORIA
	12	72020426	1	DADO FLANGIATO	FLANGED NUT	ECROU BRIDE	FLANSCHMUTTER	TUERCA CON BRIDA
	13	72040463	1	ROSETTA	WASHER	RONDELLE	UNTERLEGSCHIEBE	ARANDELA
	14	31170039	1	CANDELA NGK CR8E	SPARK PLUG NGK CR8E	BOUGIE NGK CR8E	ZÜNDKERZE NGK CR8E	BUJÍA NGK CR8E
	15	31020133	1	BOBINA	COIL	BOBINE	ZÜNDSPULE	BOBINA
	16	72150238	1	GOMMINO	RUBBER RING	JOINT EN CAOUTCHOUC	GUMMISCHEIBE	GOMA
	17	73131652	1	PIASTRINA	PLATE	PLAQUETTE	PLÄTTCHEN	PLACA
	18	72012186	2	VITE TEF M5x8	FLANGED EXAGON HEAD SCREW M5x8	BOULON DE BRIDE M5x8	FLANSCHENSCHRAUBE M5x8	TORNILLO DE REBORDE M5x8
	19	31140381	1	STATORE	STATOR	STATOR	STATOR	ESTATOR
	20	72010386	3	VITE TEF M6x22	FLANGED EXAGON HEAD SCREW M6x22	BOULON DE BRIDE M6x22	FLANSCHENSCHRAUBE M6x22	TORNILLO DE REBORDE M6x22
	21	72010157	2	VITE PICK UP M6x16	PICK UP M6x16 BOLT	VIS PICK UP M6x16	SCHRAUBE PICK UP M6x16	TORNILLO PICK UP M6x16
	22	73131651	1	PIASTRINA	PLATE	PLAQUETTE	PLÄTTCHEN	PLACA
	23	72010157	1	VITE M6x16	SCREW M6x16	VIS M6x16	SCHRAUBE M6x16	TORNILLO M6x16

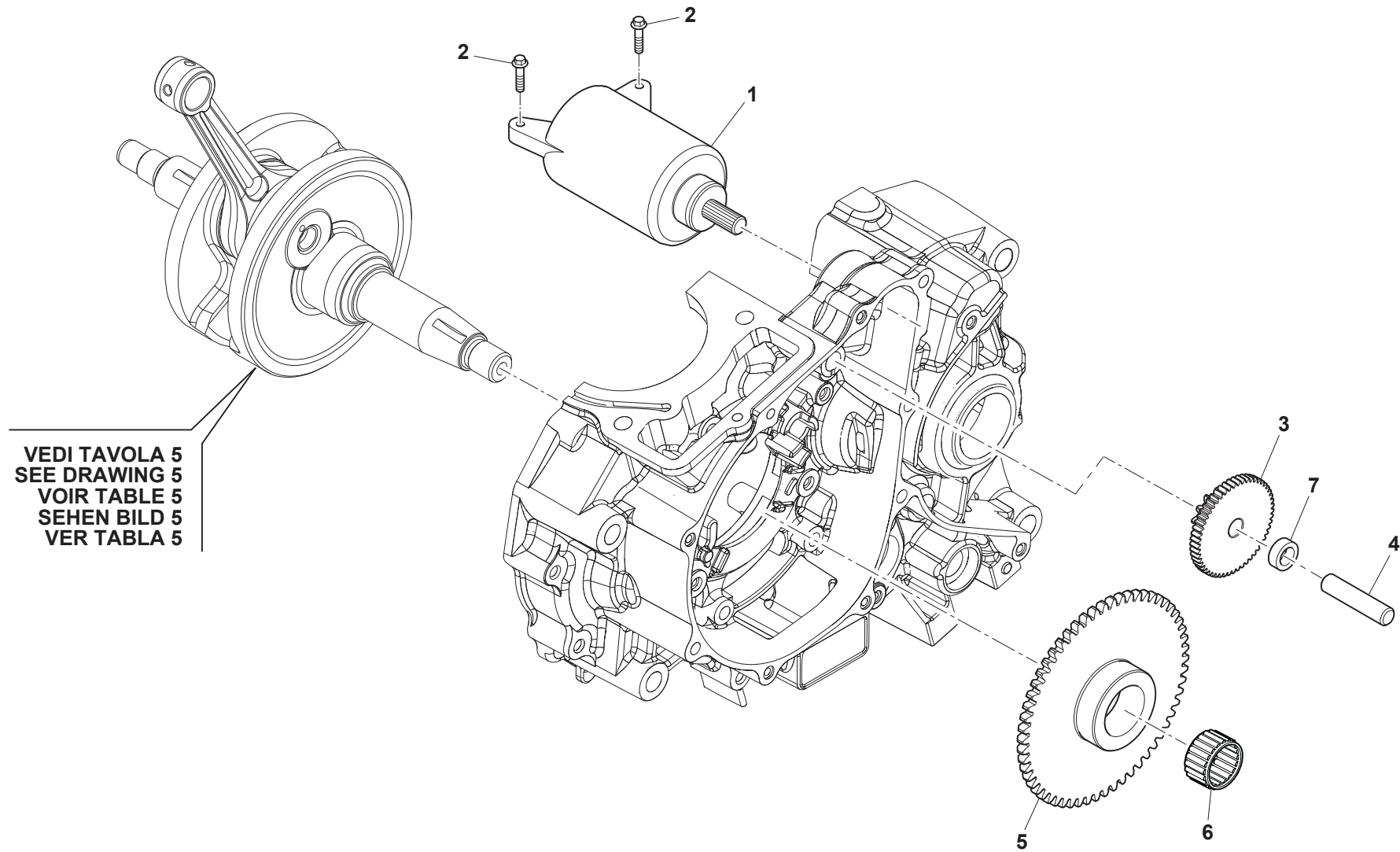

**AVVIAMENTO - STARTING
DEMARRAGE - ANLASSER
ARRANQUE**

TAVOLA
DRAWING
TABLE
BILD
TABLA

Note Notes Marke Notas	Pos. No. Index Pos.	N. Cod. Code No. Nr. Code Code Nr N. Cod.	Q.tà Q.ty Q.te M.ge C.ad	DENOMINAZIONE	NAME	DESIGNATION	BESHREIBUNG	DENOMINACION
	1	31160430	1	MOTORINO AVVIAMENTO	STARTER MOTOR	DEMARREUR ELECTRIQUE	ANLASSERMOTOR	MOTOR DE ARRANQUE
	2	72011196	2	VITE M6x25	BOLT M6x25	VIS M6x25	SCHRAUBE M6x25	TORNILLO M6x25
	3	15110038	1	INGRANAGGIO DOPPIO	DUAL GEAR	PIGNON	ZAHNRAD	ENGRANAJE
	4	24080021	1	PERNO	PIN	AXE	BOLZEN	EJE
	5	15110061	1	CORONA DENTATA Z=58	CHAIN SPROCKET T=58	COURONNE DENTÉE D=58	ZAHNKRANZ Z=58	CORONA DENTADA Z=58
	6	70090136	1	GABBIA A RULLINI	NEEDLE CAGE	CAGE À AIGUILLES	NADELKÄFIG	JAULA DE RODILLOS
	7	72040668	1	ROSETTA 10x18x2	WASHER 10x18x2	RONDELLE 10x18x2	UNTERLEGSSCHEIBE 10x18x2	ARANDELA 10x18x2

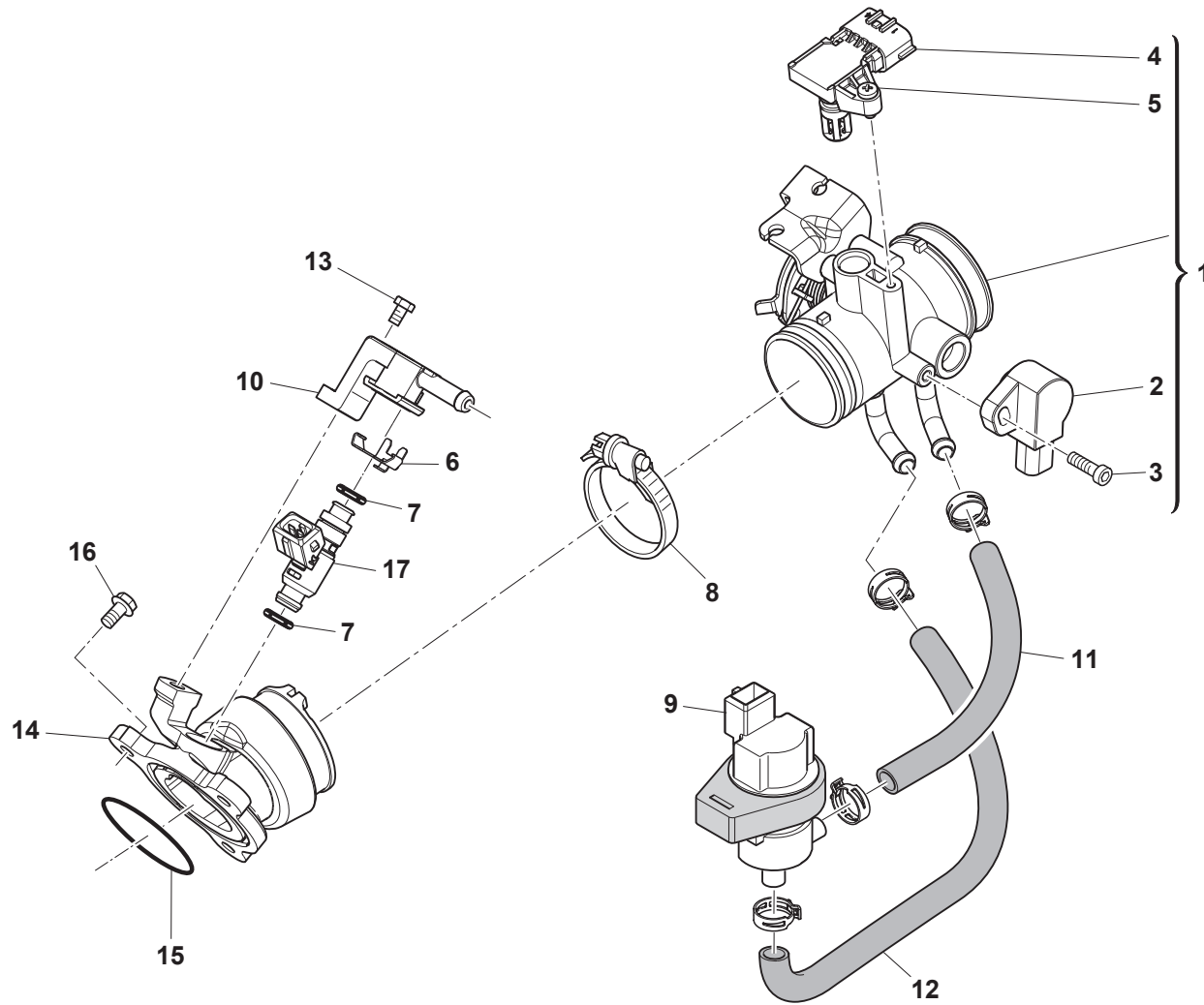



**CORPO FARFALLATO - THROTTLE BODY
CORP PAPILLON - DROSSELKLAPPENKÖRPER
CUERPO OSCILANTE**

Note Notes Notes Marke Notas	Pos. No. Index Pos.	N. Cod. Code No. Nr. Code Code Nr N. Cod.	Q.tà Q.ty Q.te M.ge C.ad	DENOMINAZIONE	NAME	DESIGNATION	BESHREIBUNG	DENOMINACION
	1	M000A00895	1	ASSIEME CORPO FARFALLATO	THROTTLE BODY ASSY	CORPS À PAPILLONS	DROSSELKÖRPER	CUERPO MARIPOSA
	2	31350080	1	SENSORE DI POSIZIONE	POSITION SENSOR	CAPTEUR	SENSOR	SENSOR
	3	72030657	1	VIITE TCIC M4x16	TCIC M4x16 BOLT	VIS TCIC M4x16	SCHRAUBE TCIC M4x16	TORNILLO TCIC M4x16
	4	31350057	1	SENSORE DI PRESSIONE	PRESSURE SENSOR	CAPTEUR DE PRESSION	DRUCKSENSOR	SENSOR PRESIÓN
	5	72030078	1	VITE TEF M5x12	FLANGED EXAGON HEAD SCREW M5x12	BOULON DE BRIDE M5x12	FLANSCHENSCHRAUBE M5x12	TORNILLO DE REBORDE M5x12
	6	F000P00852	1	CLIP	CLIP	COLLIER	SCHELLE	ABRAZADERA
	7	F000P01472	2	ANELLO OR	O-RING	JOINT TORIQUE	O-RING	JUNTA TORICA
	8	8H0099475	1	FASCETTA	CLAMP	COLLIER	SCHELLE	ABRAZADERA
	9	31350058	1	VALVOLA SOLENOIDE	SOLENOID VALVE	VANNE À SOLÉNOÏDE	MAGNETVENTIL	VÁLVULA SOLENOIDE
	10	F000P00851	1	CAPPUCCIO INIETTORE	INJECTOR CAP	CAPUCHON	KAPPE	CAPUCHÓN
	11	73090282	1	TUBO INGRESSO	INTAKE HOSE	TUYAU DE REFOULEMENT	VORLAUFROHR	TUBO ALIMENTACIÓN
	12	73090283	1	TUBO USCITA	OUTLET HOSE	TUYAU DE SORTIE	ANSCHLUSSROHR	TUBO SALIDA
	13	Z00062727	1	VITE TEF M6x16	FLANGED EXAGON HEAD SCREW M6x16	BOULON DE BRIDE M6x16	FLANSCHENSCHRAUBE M6x16	TORNILLO DE REBORDE M6x16
	14	M000P02547	1	RACCORDO CORPO FARFALLATO	THROTTLE BODY UNION	RACCORD CORPS À PAPILLONS	ANSCHLUSS DROSSELKÖRPER	RACOR CUERPO DE MARIPOSA
	15	F000P04139	1	ANELLO OR	O-RING	JOINT TORIQUE	O-RING	JUNTA TORICA
	16	Z00062727	3	VITE TEF M6x16	FLANGED EXAGON HEAD SCREW M6x16	BOULON DE BRIDE M6x16	SCHRAUBE M6x16	TORNILLO M6x16
	17	F000P00850	1	INIETTORE	INJECTOR	INJECTEUR	EINSPRITZDÜSE	INYEKTOR

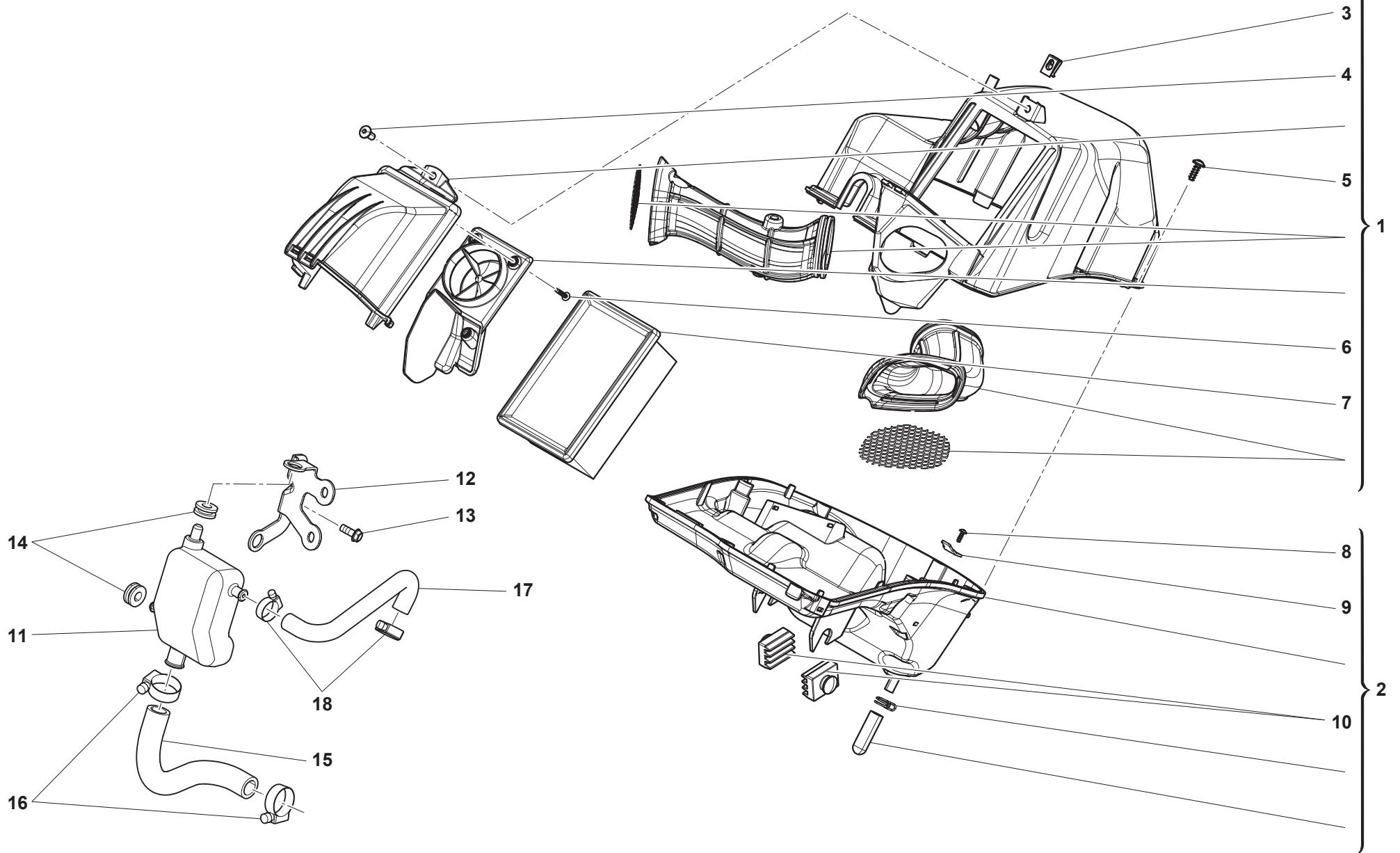

FILTRO ARIA - AIR FILTER
FILTRE AIRE - LUFTFILTER
FILTRO DE AIRE

Note Notes Notes Marke Notas	Pos. No. N. Index Pos.	N. Cod. Code No. Nr. Code Code Nr N. Cod.	Q.tà Q.ty Q.te M.ge C.ad	DENOMINAZIONE	NAME	DESIGNATION	BESHREIBUNG	DENOMINACION
	1	F000A03899	1	ASSIEME COPERCHIO AIRBOX	AIRBOX COVER ASSY	ENSEMBLE COUVERCLE BOÎTE À AIR	EINHEIT AIRBOX-DECKEL	CONJUNTO TAPA AIRBOX
	2	F000A03898	1	ASSIEME BASE AIRBOX	AIRBOX BASE ASSY	ENSEMBLE BASE BOÎTE À AIR	EINHEIT AIRBOX-UNTERTEIL	CONJUNTO BASE AIRBOX
	3	8000H2168	1	DADO A GRAFFETTA M5	CLIP NUT M5	ECROU À AGRAFE M5	SICHERUNGSMUTTER M5	TUERCA DE CLIP M5
	4	F000P04013	1	VITE TBTX ISO 7380 M5x0.8 TX25 L12	SCREW ISO 7380 M5x0.8 TX25 L12	VIS TBTX ISO 7380 M5x0.8 TX25 L12	FLACHKOPFSCHR. M. INNENSECHSK. ISO 7380 M5x0.8 TX25 L12	TORNILLO TBTX ISO 7380 M5x0,8 TX25 L12
	5	8000H0534	8	VITE PT L14	PT SCREW L14	VIS PT L14	SCHRAUBE PT L14	TORNILLO PT L14
	6	800048410	2	VITE AB 2,9X9,5	AB SCREW 2.9X9.5	VIS AB 2,9X9,5	SCHRAUBE AB 2,9X9,5	TORNILLO AB 2,9X9,5
	7	F000P03211	1	FILTRO ARIA	AIR FILTER	FILTRE À AIR	LUFTFILTER	FILTRO AIRE
	8	8A00H0534	1	VITE PT L12	PT SCREW L12	VIS PT L12	SCHRAUBE PT L12	TORNILLO PT L12
	9	F000P03215	1	PIASTRINA ATTACCO SOLENOIDE	SOLENOID MOUNTING PLATE	PLATINE FIXATION SOLÉNOÏDE	SOLENOID-ANSCHLUSSPLÄTTCHEN	PLACA FIJACIÓN SOLENOIDE
	10	73012321	2	GOMMINO PER SERBATOIO OLIO	RUBBER RING FOR OIL TANK	JOINT CAOUTCH. RÉSERV. HUILE	GUMMIELEMENT FÜR ÖLBEHÄLTER	GOMA PARA DEPÓSITO ACEITE
	11	F000P03704	1	SERBATOIO BLOWBY	BLOW-BY TANK	RÉSERVOIR BLOW-BY	BLOWBY-BEHÄLTER	DEPÓSITO BLOW-BY
	12	F000P03582	1	STAFFA SUPPORTO CANISTER	CANISTER MOUNTING BRACKET	BRIDE SUPPORT CANISTER	CANISTER-HALTEBÜGEL	SOSTÉN SOPORTE CÁNISTER
	13	ZE0067997	2	VITE TEF M5X0,8-CH8-L10	FLANG.HEX.HD SCREW M5X0,8-CH8-L10	BOULON DE BRIDE M5X0,8-CH8-L10	SECHSKANTSCHR. M. FLANSCH M5X0,8-CH8-L10	TORNILLO DE REBORDE M5X0,8-CH8-L10
	14	800041862	2	GOMMINO ANTIVIBRANTE	SILENT-BLOCK	ANTIVIBRATION	SCHWINGUNGSDAMFER	ANTIVIBRADOR
	15	F000P03705	2	TUBO BLOW BY TESTA-SERBATOIO	HEAD-TANK BLOW-BY HOSE	TUYAU BLOW-BY CULASSE-RÉSERVOIR	BLOW BY-SCHLAUCH ZYLINDER-TANK	TUBO BLOW-BY CULATA-DEPÓSITO
	16	8Q0092249	2	FASCETTA	CLAMP	COLLIER	SHELLE	ABRAZADERA
	17	F000P03706	1	TUBO BLOW BY SERBATOIO-AIRBOX	TANK-AIRBOX BLOW-BY HOSE	TUYAU BLOW-BY RÉSERVOIR-BOÎTE À AIR	BLOW BY-SCHLAUCH TANK-AIRBOX	TUBO BLOW-BY DEPÓSITO-AIRBOX
	18	8E00H1981	2	FASCETTA	CLAMP	COLLIER	SHELLE	ABRAZADERA

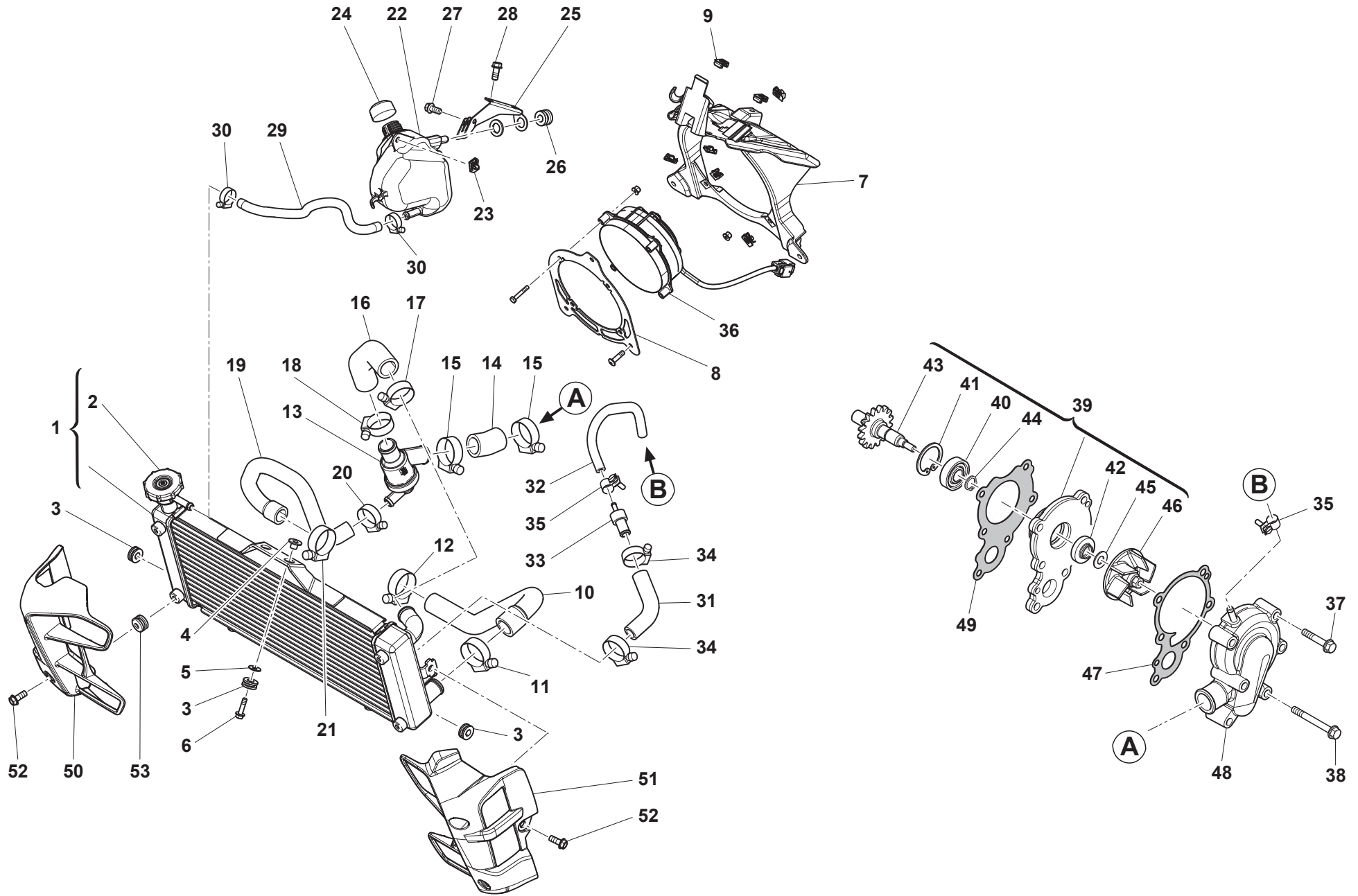

Note Notes Notas	Pos. No. Index Pos.	N. Cod. Code No. Nr. Code Code Nr N. Cod.	Q.tà Q.ty Q.te M.ge C.ad	DENOMINAZIONE	NAME	DESIGNATION	BESHREIBUNG	DENOMINACION
	1	F000A02888	1	RADIATORE	RADIATOR	RADIATEUR	KÜHLER	RADIADOR
	2	F000P02889	1	TAPPO	TAPPO	BOUCHON	STOPFEN	TAPON
	3	800041862	4	GOMMINO ANTIVIBRANTE	SILENT-BLOCK	ANTIVIBRATION	SCHWINGUNGSDAMFER	ANTIVIBRADOR
	4	8000B2799	2	DISTANZIALE CON COLLETO	FLANGED SPACER	ENTRETOISE A BRIDE	ABSTANDHALTER	DISTANCIADOR EMBRIDADO
	5	62ND15548	2	ROSETTA	WASHER	RONDELLE	UNTERLEGSSCHEIBE	ARANDELA
	6	60ND02487	2	VITE TCEI M5x20	SCREW TCEI M5x20	VIS TCEI M5x20	SCHRAUBE TCEI M5x20	TORNILLO TCEI M5x20
	7	F000P03096	1	CONVOGLIATORE VENTOLA	FAN CONVEYOR	CONVOYEUR VENTILATEUR	LÜFTERHAUBE	ENCANALADOR VENTILADOR
	8	F000P03471	1	SUPPORTO VENTOLA	FAN SUPPORT	SUPPORT VENTILATEUR	LÜFTERHALTER	SOPORTE VENTILADOR
	9	8000H2168	7	DADO A GRAFFETTA M5	CLIP NUT M5	ECROU À AGRAFE M5	SICHERUNGSMUTTER M5	TUERCA DE CLIP M5
	10	F000P02890	1	TUBO RADIATORE CILINDRO	RADIATOR CYLINDER HOSE	TUYAU RADIATEUR CYLINDRE	LEITUNG KÜHLER ZYLINDER	TUBO RADIADOR CILINDRO
	11	FA00P04023	1	FASCETTA	CLAMP	COLLIER	SHELLE	ABRAZADERA
	12	FB00P04023	1	FASCETTA	CLAMP	COLLIER	SHELLE	ABRAZADERA
	13	F000P03478	1	TERMOSTATO	THERMOSTAT	THERMOSTAT	THERMOSTAT	TERMOSTATO
	14	F000P02891	1	TUBO POMPA TERMOSTATO	PUMP THERMOSTAT HOSE	TUYAU POMPE THERMOSTAT	LEITUNG PUMPE THERMOSTAT	TUBO BOMBA TERMOSTATO
	15	FA00P04023	2	FASCETTA	CLAMP	COLLIER	SHELLE	ABRAZADERA
	16	F000P03476	1	TUBO RADIATORE TERMOSTATO	RADIATOR THERMOSTAT HOSE	TUYAU RADIATEUR THERMOSTAT	LEITUNG KÜHLER THERMOSTAT	TUBO RADIADOR TERMOSTATO
	17	FD00P04023	1	FASCETTA	CLAMP	COLLIER	SHELLE	ABRAZADERA
	18	FC00P04023	1	FASCETTA	CLAMP	COLLIER	SHELLE	ABRAZADERA
	19	F000P02892	1	TUBO BY PASS	BYPASS HOSE	TUYAU BY-PASS	BYPASS-SCHLAUCH	TUBO BY-PASS
	20	8A0092249	1	FASCETTA	CLAMP	COLLIER	SHELLE	ABRAZADERA
	21	FE00P04023	1	FASCETTA	CLAMP	COLLIER	SHELLE	ABRAZADERA
	22	F000P02893	1	SERBATOIO ESPANSIONE	EXPANSION TANK	RÉSERVOIR D'EXPANSION	AUSDEHNUNGSGEFÄß	DEPÓSITO EXPANSIÓN
	23	U00055134	1	DADO A GRAFFETTA M5	CLIP NUT M5	ECROU À AGRAFE M5	SICHERUNGSMUTTER M5	TUERCA DE CLIP M5
	24	800040427	1	TAPPO	PLUG	BOUCHON	STOPFEN	TAPON
	25	F000P02894	1	PIASTRINA DI SUPPORTO	SUPPORT PLATE	PLATINE DE SUPPORT	HALTEPLÄTTCHEN	PLACA DE SOPORTE
	26	8000H3250	1	GOMMINO	RUBBER RING	JOINT EN CAOUTCHOUC	GUMMISCHEIBE	GOMA
	27	Z00067997	1	VITE TEF M5x12	FLANGED EXAGON HEAD SCREW M5x12	BOULON DE BRIDE M5x12	FLANSCHENSCHRAUBE M5x12	TORNILLO DE REBORDE M5x12
	28	ZH0067545	2	VITE M6x12	SCREW M6x12	VIS M6x12	SCHRAUBE M6x12	TORNILLO M6x12
	29	F000P02932	1	TUBO RADIATORE-VASO ESPANSIONE	RADIATOR-EXPANSION TANK HOSE	TUYAU RADIATEUR-VASE D'EXPANSION	SCHLAUCH KÜHLER-AUSDEHNUNGSGEFÄSS	TUBO RADIADOR-DEPÓSITO EXPANSIÓN
	30	8A00H1981	2	FASCETTA	CLAMP	COLLIER	SHELLE	ABRAZADERA
	31	F000P03477	1	TUBO SFIATO POMPA	PUMP BREATHER HOSE	DURITE RENIFLARD POMPE	ENTLÜFTUNGSSCHLAUCH PUMPE	TUBO RESPIRADERO BOMBA
	32	FH00P03205	1	TUBO d4,8 D 10,3 L 175	PIPE ID 4.8 D. 10.3 L 175	TUYAU d4,8 D 10,3 L 175	SCHLAUCH D4,8 D 10,3 L 175	TUBO d4,8 D 10,3 L 175
	33	F000P03901	1	RIDUZIONE PORTAGOMMA SFIATO	BREATHER HOSE BARB ADAPTER	RÉDUCTION PORTE-TUYAU RENIFLARD	SCHLAUCHTÜLLE ENTLÜFTUNGSSCHLAUCH	REDUCCIÓN ESPIGA MANGUERA RESPIRADERO

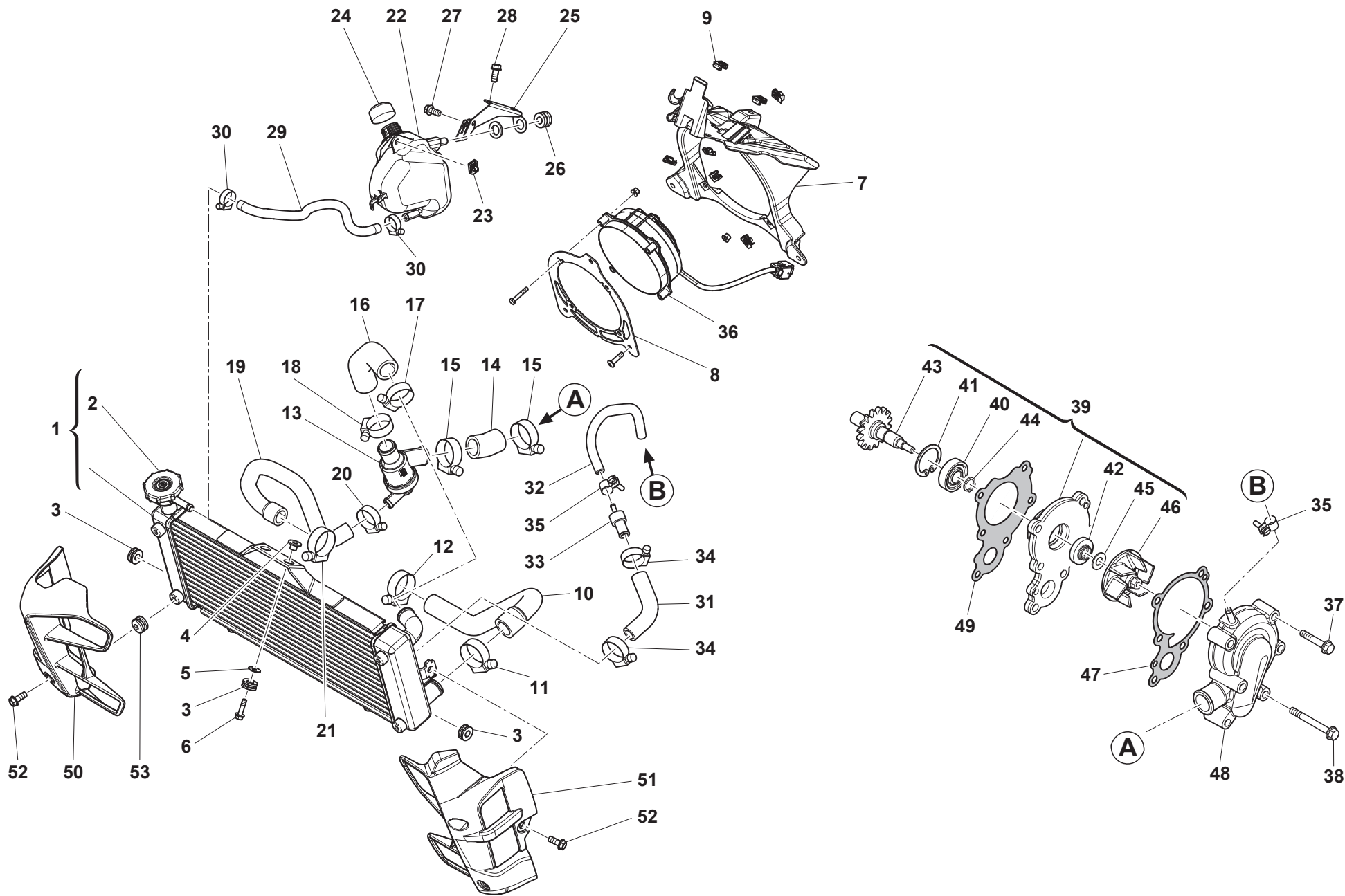

IMPIANTO DI RAFFREDDAMENTO - COOLING SYSTEM
INSTALLATION DE REFROIDISSEMENT - SCHMIERUNGSSYSTEM
EQUIPO DE ENFRIAMIENTO

Note Notes Notes Marke Notas	Pos. No. N. Index Pos.	N. Cod. Code No. Nr. Code Code Nr N. Cod.	Q.tà Q.ty Q.te M.ge C.ad	DENOMINAZIONE	NAME	DESIGNATION	BESHREIBUNG	DENOMINACION
	34	8A0092249	2	FASCETTA	CLAMP	COLLIER	SHELLE	ABRAZADERA
	35	8C00H1981	2	FASCETTA	FASCETTA	FASCETTA	FASCETTA	FASCETTA
	36	8000A7715	1	ELETTRIVENTOLA	ELECTRIC FAN	ELECTRO-VENTILATEUR	KÜHLGEBLÄSE	ELECTROVENTILADOR
	37	72012184	4	VITE TEF M5x38	FLANGED EXAGON HEAD SCREW M5x38	BOULON DE BRIDE M5x38	FLANSCHENSCHRAUBE M5x38	TORNILLO DE REBORDE M5x38
	38	72012185	2	VITE TEF M5x48	FLANGED EXAGON HEAD SCREW M5x48	BOULON DE BRIDE M5x48	FLANSCHENSCHRAUBE M5x48	TORNILLO DE REBORDE M5x48
	39	76220007	1	POMPA ACQUA COMPLETA	COMPLETE WATER PUMP	POMPE À EAU COMPLÈTE	WASSERPUMPE KOMPLETT	BOMBA AGUA COMPLETA
	40	17230008	1	CUSCINETTO 6000 26x10x8	BEARING 6000 26x10x8	ROULEMENT 6000 26x10x8	LAGER 6000 26x10x8	COJINETE 6000 26x10x8
	41	72080136	1	ANELLO DI FERMO INTERNO	INNER RETAINING RING	BAGUE D'ARRET	SICHERUNGSRING	ANILLO DE RETENCION
	42	8000A7324	1	ANELLO CORCOS 22x9x8,6	CORCOS 22x9x8,6 RING	BAGUE CORCOS 22x9x8,6	RING CORCOS 22x9x8,6	ANILLO CORCOS 22x9x8,6
	43	17220006	1	ALBERO POMPA ACQUA	WATER PUMP SHAFT	ARBRE POMPE A EAU	WELLE WASSERPUMPE	EJE BOMBA AGUA
	44	72080135	1	ANELLO DI FERMO	RETAINING RING	BAGUE D'ARRET	SICHERUNGSRING	ANILLO DE RETENCION
	45	17030009	1	ROSETTA	WASHER	RONDELLE	UNTERLEGSCHNEIBE	ARANDELA
	46	17230006	1	GIRANTE POMPA ACQUA	WATER PUMP IMPELLER	ROTOR POMPE À EAU	WASSERPUMPE LAUFRAD	BOMBA AGUA RODETE
	47	72130625	1	GUARNIZIONE COPERCHIO POMPA	PUMP COVER GASKET	JOINT COUVERCLE POMPE	DICHTUNG DECKEL PUMPE	JUNTA TAPA BOMBA
	48	14140035	1	COPERCHIO POMPA ACQUA	WATER PUMP COVER	COUVERCLE POMPE À EAU	DECKEL WASSERPUMPE	TAPA BOMBA AGUA
	49	14140035	1	GUARNIZIONE BASE POMPA ACQUA	BASE WATER PUMP GASKET	JOINT BASE POMPE À EAU	DICHTUNG BODEN WASSERPUMPE	JUNTA BASE BOMBA AGUA
	50	F000P03666	1	PROTEZIONE RADIATORE LATO DX	RADIATOR PROTECTION ON RH SIDE	PROTECTION RADIATEUR CÔTÉ DRT	KÜHLERSCHUTZ RE SEITE	PROTECCIÓN RADIADOR LADO DER.
	51	F000P03667	1	PROTEZIONE RADIATORE LATO SX	RADIATOR PROTECTION ON LH SIDE	PROTECTION RADIATEUR CÔTÉ GCHÉ	KÜHLERSCHUTZ LI SEITE	PROTECCIÓN RADIADOR LADO IZQ.
	52	8A00A8421	6	VITE TE M5x12	SCREW TE M5x12	VIS TE M5x12	SCHRAUBE TE M5x12	TORNILLO TE M5x12
	53	F000P03929	4	TAMPONE ELASTICO	RUBBER BLOCK	TAMPON ÉLASTIQUE	GUMMISTOPFEN	TOPE ELÁSTICO

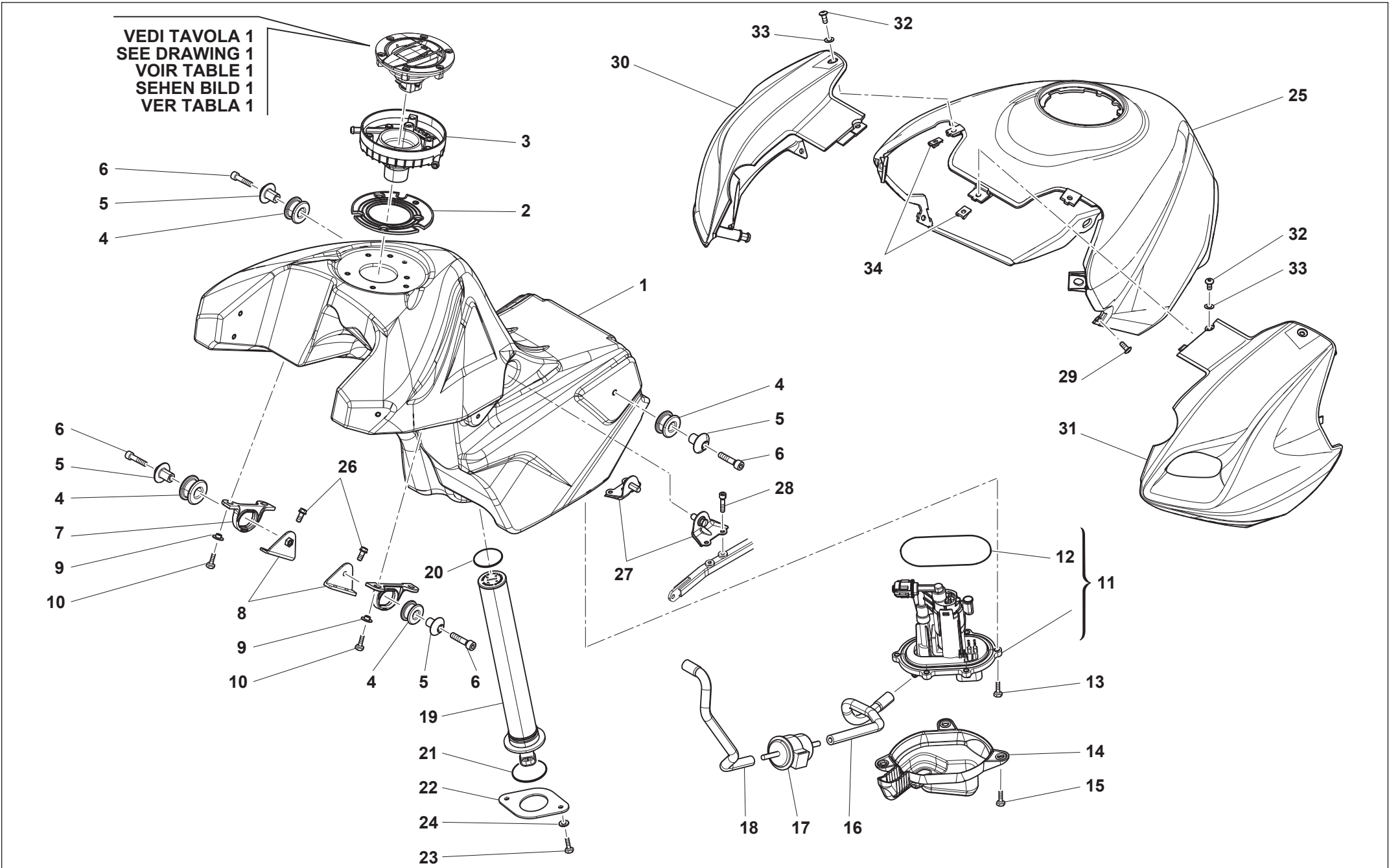

SERBATOIO CARBURANTE - FUEL TANK
RESERVOIR CARBURANT - KRAFTSTOFFBEHALTER
DEPOSITO GASOLINA

Note Notes Notes Marke Notas	Pos. No. N. Index Pos.	N. Cod. Code No. Nr. Code Code Nr N. Cod.	Q.tà Q.ty Q.te M.ge C.ad	DENOMINAZIONE	NAME	DESIGNATION	BESHREIBUNG	DENOMINACION
	1	FA00P02882	1	SERBATOIO CARBURANTE	FUEL TANK	RÉSERVOIR DE CARBURANT	KRAFTSTOFFTANK	DEPÓSITO COMBUSTIBLE
	2	F000P03054	1	GUARNIZIONE TAPPO SERBATOIO	TANK PLUG SEAL	JOINT BOUCHON RÉSERVOIR	TANKVERSCHLUSSDICHTUNG	JUNTA TAPÓN DEPÓSITO
	3	F000P03055	1	INTERFACCIA PER TAPPO SERBATOIO	INTERFACE FOR TANK PLUG	INTERFACE POUR BOUCHON RÉSERVOIR	ZWISCHENFLANSCH TANKVERSCHLUSS	INTERFAZ PARA TAPÓN DEPÓSITO
	4	800089302	4	ANTIVIBRANTE	SILENT-BLOCK	ANTIVIBRATION	SCHWINGUNGSDAMFER	ANTIVIBRADOR
	5	F000P03563	4	DISTANZIALE CARENATO	HAT-SHAPED SPACER	ENTRETOISE CARÉNAGE	VERKLEIDUNGSDISTANZSTÜCK	DISTANCIADOR CARENADO
	6	60ND02511	4	VITE TCEI M6x30	SCREW TCEI M6x30	VIS TCEI M6x30	SCHRAUBE TCEI M6x30	TORNILLO TCEI M6x30
	7	F000P03056	2	SUPPORTO ANTERIORE SERBATOIO	TANK FRONT SUPPORT	SUPPORT AVANT RÉSERVOIR	VORDERER TANKHALTER	SOPORTE DELANTERO DEPÓSITO
	8	F000P03581	2	STAFFA SUPPORTO SERBATOIO	TANK MOUNTING BRACKET	BRIDE SUPPORT RÉSERVOIR	TANKSTÜTZBÜGEL	SOSTÉN SOPORTE DEPÓSITO
	9	800069282	4	BUSSOLA	BUSHING	DOUILLE	BUCHSE	CASQUILLO
	10	Z00067997	4	VITE TEF M5x12	FLANGED EXAGON HEAD SCREW M5x12	BOULON DE BRIDE M5x12	FLANSCHENSCHRAUBE M5x12	TORNILLO DE REBORDE M5x12
	11	F000P04179	1	POMPA BENZINA	FUEL PUMP	POMPE À CARBURANT	BENZINPUMPE	BOMBA GASOLINA
	12	F000P02034	1	GUARNIZIONE POMPA BENZINA	FUEL PUMP GASKET	JOINT POMPE DE CARBURANT	DICHTUNG PUMPE	JUNTA BOMBA COMBUSTIBLE
	13	ZK0067997	6	VITE TEF M5x14	FLANGED EXAGON HEAD SCREW M5x14	BOULON DE BRIDE M5x14	FLANSCHENSCHRAUBE M5x14	TORNILLO DE REBORDE M5x14
	14	F000P03709	1	COPERCHIO POMPA BENZINA	FUEL PUMP COVER	COUVERCLE POMPE À CARBURANT	BENZINPUMPENDECKEL	TAPA BOMBA GASOLINA
	15	8000A8421	3	VITE TE M5x8	SCREW TE M5x8	VIS TE M5x8	SCHRAUBE TE M5x8	TORNILLO TE M5x8
	16	F000P03702	1	TUBO MANDATA BENZINA POMPA FILTRO	FUEL DELIVERY HOSE TO FILTER PUMP	TUYAU REFOUL. CARB. POMPE FILTRE	BENZINDRUCKLEITUNG PUMPE FILTER	TUBO IMPULSIÓN GASOLINA BOMBA FILTRO
	17	F000P04412	1	FILTRO BENZINA	FUEL FILTER	FILTRE DE CARBURANT	BENZINFILTER	FILTRO COMBUSTIBLE
	18	F000P03703	1	TUBO FILTRO-INIETTORE	FUEL FILTER-INJECTOR HOSE	TUBE FILTRE-INJECTEUR	ROHR FILTER-EINSPRITZDÜSE	TUBO FILTRO-INYECTOR
	19	E000P03578	1	SENSORE LIVELLO BENZINA	FUEL SENDER ASSY	CAPTEUR	SENSOR	SENSOR
	20	F000P03579	1	GUARNIZIONE D31	GASKET D31	JOINT D31	DICHTUNG D31	JUNTA D31
	21	FB00P03580	1	GUARNIZIONE D37	GASKET D37	JOINT D37	DICHTUNG D37	JUNTA D37
	22	F000P03560	1	STAFFA PER SENSORE	SENSOR BRACKET	BRIDE POUR CAPTEUR	BÜGEL FÜR SENSOR	SOSTÉN PARA SENSOR
	23	Z00067997	2	VITE TEF M5x12	FLANGED EXAGON HEAD SCREW M5x12	BOULON DE BRIDE M5x12	FLANSCHENSCHRAUBE M5x12	TORNILLO DE REBORDE M5x12
	24	62ND15548	2	ROSETTA	WASHER	RONDELLE	UNTERLEGSCHEIBE	ARANDELA
WHITE	25	F000A03948	1	CARENA SERBATOIO	TANK COVER	CARÉNAGE RÉSERVOIR	TANKVERKLEIDUNG	CARENADO DEPÓSITO
BLACK	25	FOA0P03948	1	CARENA SERBATOIO	TANK COVER	CARÉNAGE RÉSERVOIR	TANKVERKLEIDUNG	CARENADO DEPÓSITO
	26	ZH0067545	4	VITE M6x12	SCREW M6x12	VIS M6x12	SCHRAUBE M6x12	TORNILLO M6x12
	27	F000A03749	2	STAFFA CENTRALE SUPPORTO SERBATOIO	CENTRAL TANK MOUNTING BRACKET	BRIDE CENTRALE SUPPORT RÉSERVOIR	MITTLERER TANKSTÜTZBÜGEL	SOSTÉN CENTRAL SOPORTE DEPÓSITO
	28	ZH0067545	4	VITE M6x12	SCREW M6x12	VIS M6x12	SCHRAUBE M6x12	TORNILLO M6x12
	29	8000A8421	5	VITE TE M5x8	SCREW TE M5x8	VIS TE M5x8	SCHRAUBE TE M5x8	TORNILLO TE M5x8
WHITE	30	F000A03945	1	CARENA PRESA D'ARIA LATO DX	RH SIDE AIR SCOOP	CARÉNAGE PRISE D'AIR CÔTÉ DRT	LUFTKANALVERKLEIDUNG RECHTE SEITE	CARENADO TOMA DE AIRE LADO DER.
BLACK	30	FOA0A03945	1	CARENA PRESA D'ARIA LATO DX	RH SIDE AIR SCOOP	CARÉNAGE PRISE D'AIR CÔTÉ DRT	LUFTKANALVERKLEIDUNG RECHTE SEITE	CARENADO TOMA DE AIRE LADO DER.
WHITE	31	F000A03947	1	CARENA PRESA D'ARIA LATO SX	LH SIDE AIR SCOOP	CARÉNAGE PRISE D'AIR CÔTÉ GCHE	LUFTKANALVERKLEIDUNG LINKE SEITE	CARENADO TOMA DE AIRE LADO IZQ.

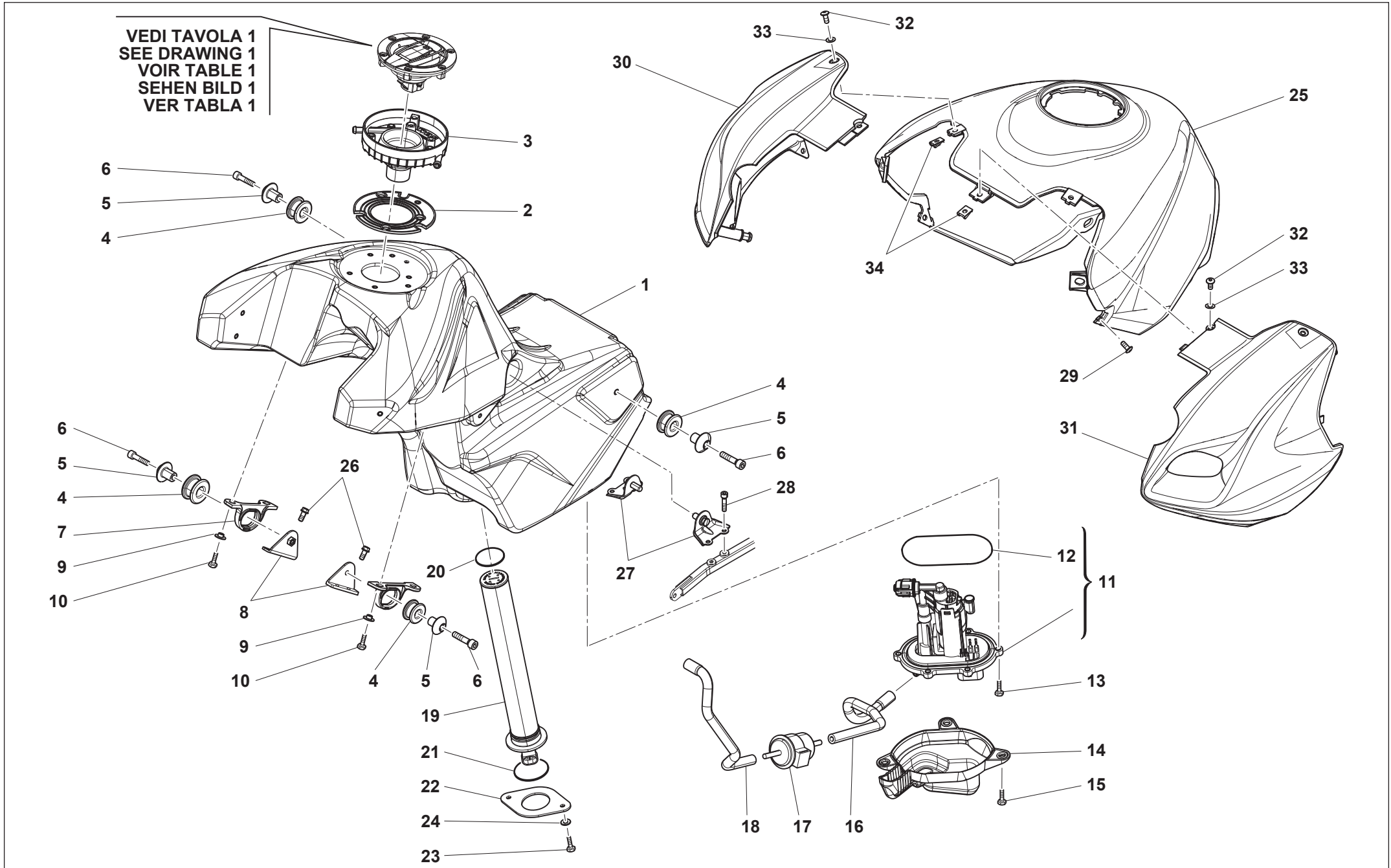

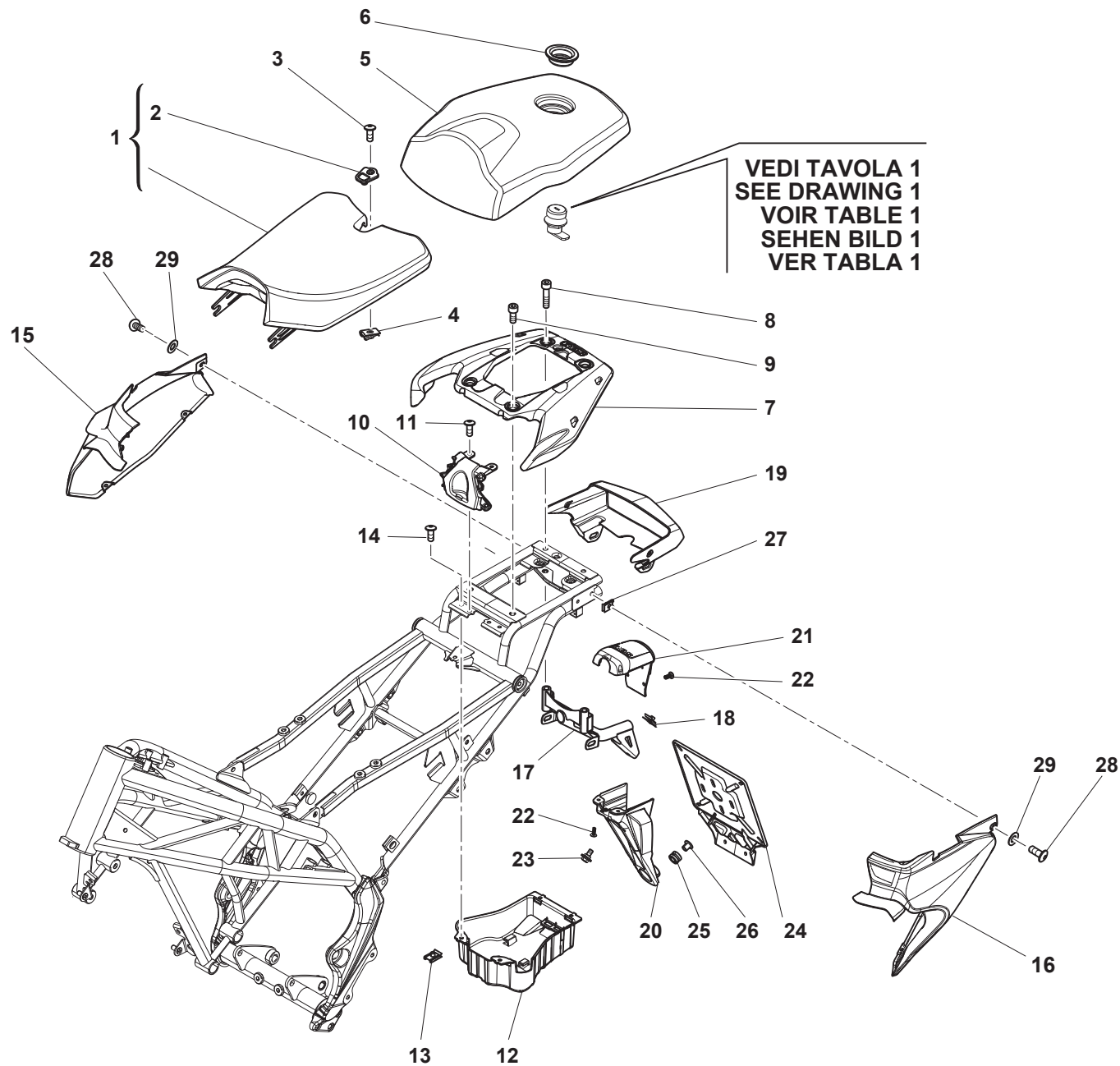

SELLE - PANNELLI POSTERIORI - PORTATARGA - SEATS - REAR PANEL - PLATE HOLDER
SELLES - PANNEAUX ARRIÈRE - SUPPORT DE PLAQUE D'IMMATRICULATION - SITZBÄNKE - HINTERE
VERKLEIDUNGSTEILE - KENNZEICHENHALTER - ASIENTOS - PANELES TRASEROS - PORTAMATRÍCULA

Note Notes Notes Marke Notas	Pos. No. N. Index Pos.	N. Cod. Code No. Nr. Code Code Nr N. Cod.	Q.tà Q.ty Q.te M.ge C.ad	DENOMINAZIONE	NAME	DESIGNATION	BESHREIBUNG	DENOMINACION
	1	F000A03815_P	1	SELLA PILOTA	RIDER SEAT	SELLE PILOTE	FAHRERSITZBANK	ASIENTO PILOTO
	2	F000P03859	1	PLACCHETTA FISSAGGIO SELLA	SEAT RETAINING PLATE	PLATINE FIXATION SELLE	SITZBANKBEFESTIGUNGSPLÄTTCHEN	PLACA FIJACIÓN ASIENTO
	3	F000P04131	1	VITE TBEI M5x35	BOLT TBEI M5x35	VIS TBEI M5x35	SCHRAUBE TBEI M5x35	TORNILLO TBEI M5x35
	4	8000H2168	1	DADO A GRAFFETTA M5	CLIP NUT M5	ECROU À AGRAFE M5	SICHERUNGSMUTTER M5	TUERCA DE CLIP M5
	5	F000A03092_P	1	SELLA PASSEGGERO	PASSENGER SEAT	SELLE PASSAGER	BEIFAHRSITZBANK	ASIENTO PASAJERO
	6	F000P03860	1	ANELLO PER FISSAGGIO SERRATURA	LOCK RETAINING RING	BAGUE DE FIXATION SERRURE	RING FÜR SCHLOSSBEFESTIGUNG	ANILLO PARA FIJACIÓN CERRADURA
	7	F000P03671	1	MANIGLIA PASSEGGERO	PASSENGER HANDLE	POIGNÉE PASSAGER	BEIFÄHRERHALTEGRIF	MANIJA PASAJERO
	8	FE00P03798	2	VITE TCEI RIBASSATA M8x65	NARROW SCREW TCEI M8x65	VIS TCEI SURBAISSÉE M8x65	ABGEFL. ZYLK.SCHRAUBE M. INNENSECHSK. M8x65	TORNILLO TCEI BAJO M8x65
	9	FA00P03798	2	VITE TCEI RIBASSATA M8x16	NARROW SCREW TCEI M8x16	VIS TCEI SURBAISSÉE M8x16	ABGEFL. ZYLK.SCHRAUBE M. INNENSECHSK. M8x16	TORNILLO TCEI BAJO M8x16
	10	F000P03682	1	CHIUSURA CENTRALE CODA	TAIL CENTRE COVER	FERMETURE CENTRALE QUEUE	MITTLERER VERSCHLUSS HECK	CIERRE CENTRAL COLA
	11	F000P03911	4	VITE AUTOFILETTANTE	SCREW, TAPPING	VIS TARAUD	GEWINDESCHRAUBE	TORNILLO AUTOROSCANTE
	12	F000P03684	1	VASCHETTA PORTA DOCUMENTI	GLOVE COMPARTMENT	BAC PORTE-DOCUMENTS	STAUFACH	BANDEJA PARA DOCUMENTOS
	13	F000P03887	4	DADO A GRAFFETTA M5	CLIP NUT M5	ECROU À AGRAFE M5	SICHERUNGSMUTTER M5	TUERCA DE CLIP M5
	14	F000P04013	4	VITE TBTX M5x12	SCREW TBTX M5x12	VIS TBTX M5x12	FLACHKOPFSCHR. M. INNENSECHSK. M5x12	TORNILLO TBTX M5x12
WHITE	15	F000A03953	1	ASSIEME CODA LATO DX	RH SIDE TAIL ASSY	ENSEMBLE QUEUE CÔTÉ DRT	HECKEINHEIT RE SEITE	CONJUNTO COLA LADO DER.
BLACK	15	FOA0A03953	1	ASSIEME CODA LATO DX	RH SIDE TAIL ASSY	ENSEMBLE QUEUE CÔTÉ DRT	HECKEINHEIT RE SEITE	CONJUNTO COLA LADO DER.
WHITE	16	F000A03955	1	ASSIEME CODA LATO SX	LH SIDE TAIL ASSY	ENSEMBLE QUEUE CÔTÉ GCHE	HECKEINHEIT LI SEITE	CONJUNTO COLA LADO IZQ.
BLACK	16	FOA0A03955	1	ASSIEME CODA LATO SX	LH SIDE TAIL ASSY	ENSEMBLE QUEUE CÔTÉ GCHE	HECKEINHEIT LI SEITE	CONJUNTO COLA LADO IZQ.
	17	F000A03075	1	SUPPORTO PORTA TARGA	NUMBER PLATE HOLDER SUPPORT	SUPPORT DE PLAQUE D'IMMATRICULATION	TRÄGER KENNZEICHENHALTER	SOPORTE PORTAMATRÍCULA
	18	U00055134	2	DADO A GRAFFETTA M5	CLIP NUT M5	ECROU À AGRAFE M5	KLEMMMUTTER M5	TUERCA DE CLIP M5
	19	F000P03676	1	CORNICE FARO POSTERIORE	TAIL LIGHT TRIM	CADRE PHARE ARRIÈRE	EINFASSUNG RÜCKLICHT	MARCO FARO TRASERO
	20	F000P03683	1	PORTATARGA	NUMBER PLATE HOLDER	SUPPORT PLAQUE D'IMM.	NUMMERNSCHILDHALTER	PORTAMATRÍCULA
	21	F000P03712	1	SUPPORTO LUCE TARGA	NUMBER PLATE LIGHT SUPPORT	SUPPORT FEU DE PLAQUE D'IMMATRICULATION	HALTER KENNZEICHENBELEUCHTUNG	SOPORTE LUZ MATRÍCULA
	22	FA00P03911	4	VITE AUTOFILETTANTE	SCREW, TAPPING	VIS TARAUD	GEWINDESCHRAUBE	TORNILLO AUTOROSCANTE
	23	8A00A8421	2	VITE TE M5x12	SCREW TE M5x12	VIS TE M5x12	SCHRAUBE TE M5x12	TORNILLO TE M5x12
	24	8000H3018	1	PIASTRA PORTATARGA	NUMBER PLATE HOLDER	SUPPORT PLAQUE D'IMM.	NUMMERNSCHILDHALTER	PORTAMATRÍCULA
	25	800041862	2	GOMMINO ANTIVIBRANTE	SILENT-BLOCK	ANTIVIBRATION	SCHWINGUNGSDAMFER	ANTIVIBRADOR
	26	8000B2799	2	DISTANZIALE CON COLLETTA	FLANGED SPACER	ENTRETOISE A BRIDE	ABSTANDHALTER	DISTANCIADOR EMBRIDADO
	27	8000H2168	2	DADO A GRAFFETTA M5	CLIP NUT M5	ECROU À AGRAFE M5	ICHERUNGSMUTTER M5	TUERCA DE CLIP M5
	28	F000P03888	6	ROSETTA	WASHER	RONDELLE	UNTERLEGSCHIEBE	ARANDELA
	29	F000P04013	6	VITE TBTX M5x12	SCREW TBTX M5x12	VIS TBTX M5x12	FLACHKOPFSCHR. M. INNENSECHSK. M5x12	TORNILLO TBTX M5x12

VEDI TAVOLA 32
SEE DRAWING 32
VOIR TABLE 32
SEHEN BILD 32
VER TABLA 32

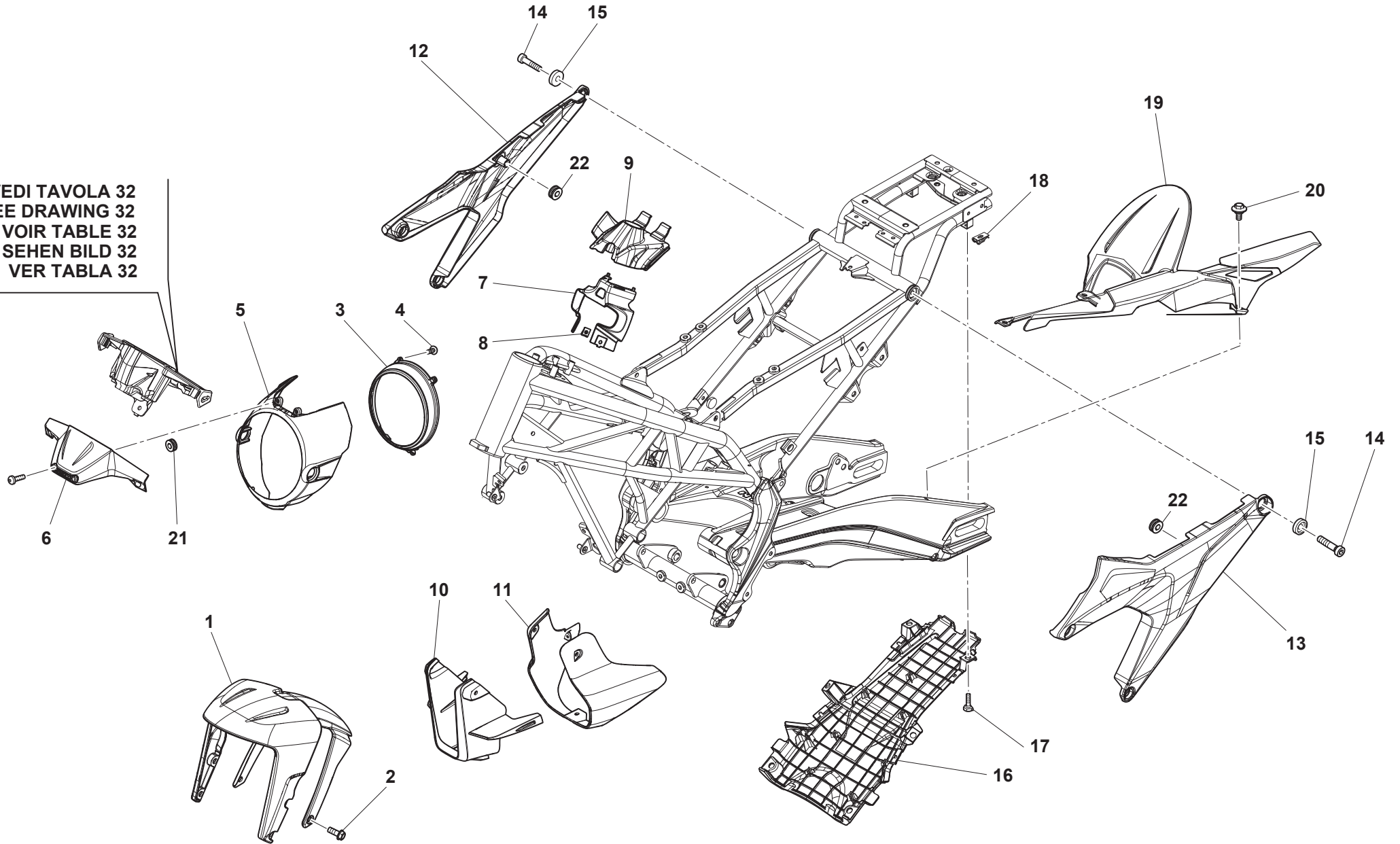

Note Notes Marke Notas	Pos. No. Index Pos.	N. Cod. Code No. Nr. Code Code Nr N. Cod.	Q.tà Q.ty Q.te M.ge C.ad	DENOMINAZIONE	NAME	DESIGNATION	BESHREIBUNG	DENOMINACION
	1	F000P03672	1	PARAFANGO ANTERIORE	FRONT MUDGUARD	GARDE-BOUE AVANT	VORDERRADKOTFLÜGEL	GUARDABARROS DELANTERO
	2	8A00A8421	6	VITE TE M5x12	SCREW TE M5x12	VIS TE M5x12	SCHRAUBE TE M5x12	TORNILLO TE M5x12
	3	FOA0P03781	1	ANELLO COPRIFARO	HEADLIGHT COVER RING	BAGUE CACHE PHARE	SCHEINWERFERRING	ANILLO EMBELLECEDOR FARO
	4	F000P03912	4	VITE AUTOFILETTANTE	SCREW, TAPPING	VIS TARAUD	GEWINDESCHRAUBE	TORNILLO AUTOROSCANTE
	5	F000P03668	1	CUPOLINO FARO	HEADLIGHT FAIRING	BULLE PHARE	SCHEINWERFERVERKLEIDUNG	CÚPULA FARO
	6	F000P03669	1	CARENA STRUMENTO	INSTRUMENT COVER	CARÉNAGE INSTRUMENT	INSTRUMENTVERKLEIDUNG	CARENADO INSTRUMENTO
	7	F000P03677	1	CARENA PASSACAVI	GROMMET	CARÉNAGE PASSE-CÂBLES	VERKLEIDUNG KABELFÜHRUNG	CARENADO PASACABLES
	8	F000P03887	2	DADO A GRAFFETTA M5	CLIP NUT M5	ECROU À AGRAFE M5	SICHERUNGSMUTTER M5	TUERCA DE CLIP M5
	9	F000P03679	1	GOMMOTTO	RUBBER BLOCK	PLOT CAOUTCHOUC	GUMMIELEMENT	GOMA
	10	F000P03680	1	INTERNO PUNTALE	LUG INTERNAL PART	INTÉRIEUR EMBOUT	INNENTEIL BUGSPOILER	INTERNO PUNTA
	11	F000P03681	1	ESTERNO PUNTALE	LUG EXTERNAL PART	EXTÉRIEUR EMBOUT	AUSSENTEIL BUGSPOILER	ESTERNO PUNTA
	12	F000P03664	1	FIANCHETTO LATO DX	RH SIDE BODY PANEL	FLANC CÔTÉ DRT	SEITENABDECKUNG RECHTE SEITE	CARENADO LATERAL DER.
	13	F000P03665	1	FIANCHETTO LATO SX	LH SIDE BODY PANEL	FLANC CÔTÉ GCHE	SEITENABDECKUNG LINKE SEITE	CARENADO LATERAL IZQ.
	14	F000P03798	6	VITE TCEI M8x20	SCREW TCEI M8x20	VIS TCEI M8x20	SCHRAUBE TCEI M8x20	TORNILLO TCEI M8x20
	15	F000P03088	6	RONDELLA	WASHER	RONDELLE	UNTERLEGSCHEIBE	ARANDELA
	16	F000P03675	1	PARAFANGO INTERNO	INTERNAL MUDGUARD	GARDE-BOUE INTÉRIEUR	INTERNER KOTFLÜGEL	GUARDABARROS INTERIOR
	17	8000A8421	6	VITE TE M5x8	SCREW TE M5x8	VIS TE M5x8	SCHRAUBE TE M5x8	TORNILLO TE M5x8
	18	F000P03887	4	DADO A GRAFFETTA M5	CLIP NUT M5	ECROU À AGRAFE M5	SICHERUNGSMUTTER M5	TUERCA DE CLIP M5
	19	F000P03678	1	PARAFANGO POSTERIORE	REAR MUDGUARD	GARDE-BOUE ARRIÈRE	HINTERRADKOTFLÜGEL	GUARDABARROS TRASERO
	20	8000A8421	4	VITE TE M5x8	SCREW TE M5x8	VIS TE M5x8	SCHRAUBE TE M5x8	TORNILLO TE M5x8
	21	F000P03929	1	TAMPONE ELASTICO	RUBBER BLOCK	TAMPON ÉLASTIQUE	GUMMISTOPFEN	TOPE ELÁSTICO
	22	F000P03919	2	TAMPONE ELASTICO	RUBBER BLOCK	TAMPON ÉLASTIQUE	GUMMISTOPFEN	TOPE ELÁSTICO

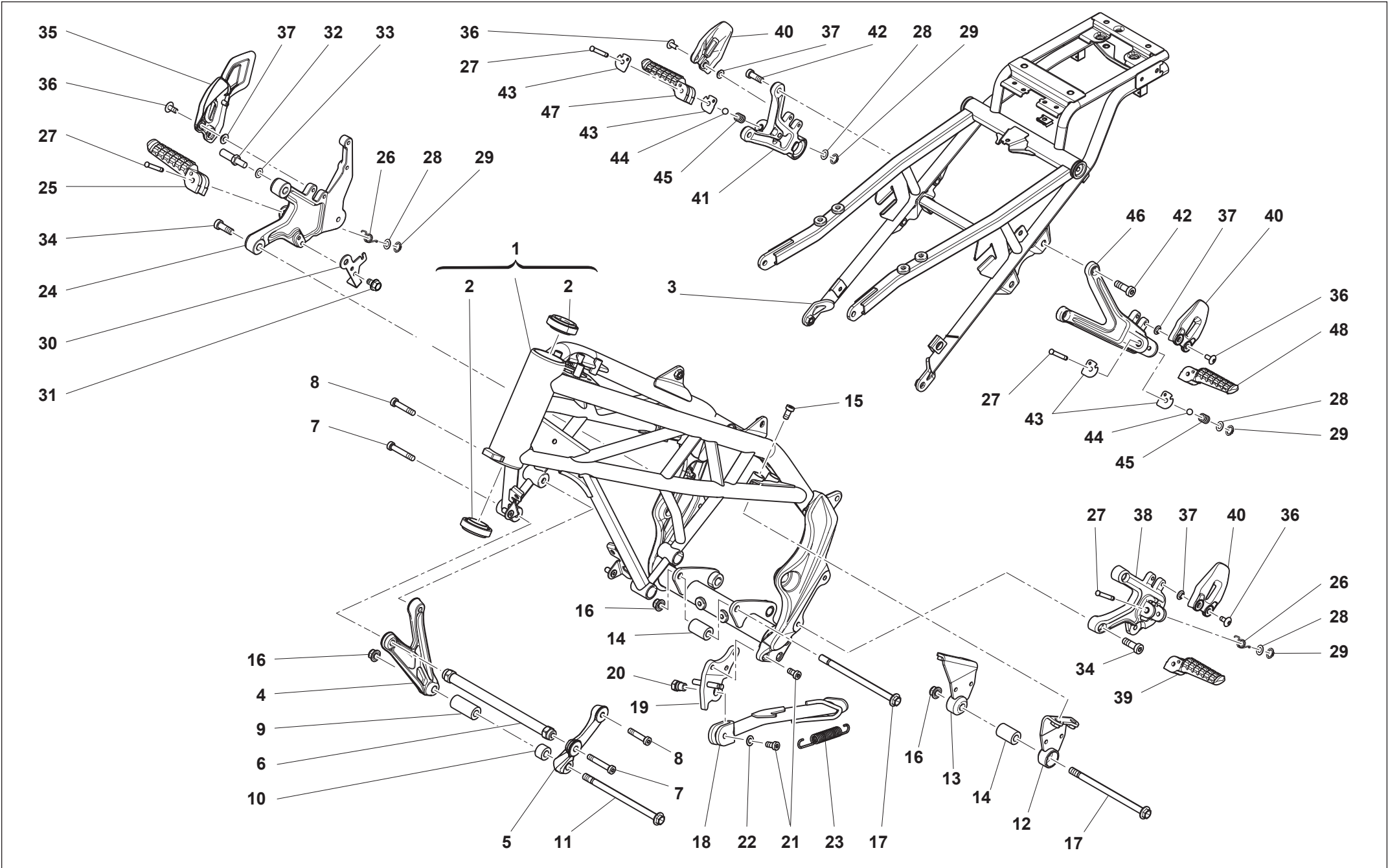

Note Notes Notes Marke Notas	Pos. No. Index Pos.	N. Cod. Code No. Nr. Code Code Nr N. Cod.	Q.tà Q.ty Q.te M.ge C.ad	DENOMINAZIONE	NAME	DESIGNATION	BESHREIBUNG	DENOMINACION
	1	F000A02806	1	TELAIO ANTERIORE CON CUSCINETTI	FRONT FRAME WITH BEARINGS	CADRE AVANT AVEC ROULEMENTS	VORDERER RAHMENTEIL MIT LAGERN	BASTIDOR DELANTERO CON COJINETES
	2	800087243	2	CUSCINETTO A RULLI CONICI	TAPERED ROLLER BEARING	ROULEMENT À ROULEAUX CONIQUES	KEGELROLLENLAGER	COJINETE DE RODILLOS CÓNICOS
	3	F000A02809	1	TELAIO POSTERIORE	REAR FRAME	CADRE ARRIÈRE	HECKRAHMEN	BASTIDOR TRASERO
	4	F000P03029	1	SUPPORTO MOTORE ANTERIORE DX	RH FRONT ENGINE SUPPORT	SUPPORT MOTEUR AVANT DRT	VORDERE MOTORLAGERUNG RECHTS	SOPORTE MOTOR DELANTERO DER.
	5	F000P03028	1	SUPPORTO MOTORE ANTERIORE SX	LH FRONT ENGINE SUPPORT	SUPPORT MOTEUR AVANT GCHE	VORDERE MOTORLAGERUNG LINKS	SOPORTE MOTOR DELANTERO IZQ.
	6	F0A0P03541	1	TRAVERSO ANTERIORE	FRONT CROSSBEAM	TRAVERSE AVANT	VORDERE QUERSTREBE	TRAVESAÑO DELANTERO
	7	60ND02557	2	VITE TCEI M8x30	SCREW TCEI M8x30	VIS TCEI M8x30	SCHRAUBE TCEI M8x30	TORNILLO TCEI M8x30
	8	60ND02555	2	VITE TCEI M8x20	SCREW TCEI M8x20	VIS TCEI M8x20	SCHRAUBE TCEI M8x20	TORNILLO TCEI M8x20
	9	FA00P01286	1	DISTANZIALE	SPACER	ENTRETOISE	ABSTANDHALTER	DISTANCIADOR
	10	FB00P01286	1	DISTANZIALE	SPACER	ENTRETOISE	ABSTANDHALTER	DISTANCIADOR
	11	YV0069138	1	VITE TEF M10x165	SCREW M10x165	BOULON DE BRIDE M10x165	FLANSCHENSCHRAUBE M10x165	TORNILLO DE REBORDE M10x165
	12	F000P03030	1	SUPPORTO MOTORE POSTERIORE SX	LH REAR ENGINE SUPPORT	SUPPORT MOTEUR ARRIÈRE GCHE	HINTERE MOTORLAGERUNG LINKS	SOPORTE MOTOR TRASERO IZQ.
	13	F000P03031	1	SUPPORTO MOTORE POSTERIORE DX	RH REAR ENGINE SUPPORT	SUPPORT MOTEUR ARRIÈRE DRT	HINTERE MOTORLAGERUNG RECHTS	SOPORTE MOTOR TRASERO DER.
	14	F000P01286	2	DISTANZIALE	SPACER	ENTRETOISE	ABSTANDHALTER	DISTANCIADOR
	15	60ND07350	4	VITE TCEI M8x16	SCREW TCEI M8x16	VIS TCEI M8x16	SCHRAUBE TCEI M8x16	TORNILLO TCEI M8x16
	16	Z00042022	3	DADO FLANGIATO M10	FLANGED NUT M10	ECROU BRIDE M10	FLANSCHMUTTER M10	TUERCA CON BRIDA M10
	17	YP0069138	2	VITE TEF M10x150	SCREW M10x150	BOULON DE BRIDE M10x150	FLANSCHENSCHRAUBE M10x150	TORNILLO DE REBORDE M10x150
	18	F000P02811	1	CAVALLETTO LATERALE	LATERAL STAND	BÉQUILLE	STÄNDER	CABALLETE LATERAL
	19	F000P03584	1	STAFFA SUPPORTO CAVALLETTO	STAND MOUNTING BRACKET	BRIDE SUPPORT BÉQUILLE	SEITENSTÄNDERSTÜTZBÜGEL	SOSTÉN SOPORTE CABALLETE
	20	F000P03644	1	PERNO	PIN	AXE	BOLZEN	EJE
	21	FA00P03798	4	VITE TCEI RIBASSATA M8x16	NARROW SCREW TCEI M8x16	VIS TCEI SURBAISSÉE M8x16	ABGEFL. ZYL.K.SCHRAUBE M. INNENSECHSK. M8x16	TORNILLO TCEI BAJO M8x16
	22	Z00056377	1	ROSETTA	WASHER	RONDELLE	UNTERLEGSCHIEBE	ARANDELA
	23	F000P02470	1	MOLLA	SPRING	RESSORT	FEDER	MUELLE
	24	F000P03039	1	SUPPORTO PEDANA DESTRA	R.H. FOOTREST SUPPORT	SUPPORT REPOSE-PIEDS DROITE	HALTERUNG FUßRASTE RECHTS	SOPORTE ESTRIBO DERECHA
	25	80A062562	1	PEDANA DESTRA	R.H. FOOTREST	REPOSE-PIEDS DROITE	FUßRASTE RECHTS	ESTRIBO DERECHA
	26	800060700	2	MOLLA PEDANA	SPRING	RESSORT	FEDER	MUELLE
	27	Z00053546	4	PERNO	PIN	AXE	BOLZEN	EJE
	28	62N115504	4	ROSETTA	WASHER	RONDELLE	UNTERLEGSCHIEBE	ARANDELA
	29	66ND21308	4	ANELLO ELASTICO	CIRCLIP	CIRCLIP	SPRENGRING	ANILLO ELASTICO
	30	F000P03381	1	FONDO CORSA LEVA FRENO POSTERIORE	REAR BRAKE PEDAL LIMIT STOP	FIN DE COURSE LEVIER DU FREIN ARRIÈRE	HEBELANSCHLAG HINTERRADBREMSE	TOPE CARRERA PALANCA FRENO TRASERO
	31	ZD0067997	2	VITE TEF M5x8	FLANGED EXAGON HEAD SCREW M5x8	BOULON DE BRIDE M5x8	FLANSCHENSCHRAUBE M5x8	TORNILLO DE REBORDE M5x8
	32	F000P03375	1	PERNO LEVA FRENO	BRAKE LEVER PIN	AXE LEVIER DU FREIN	BREMSHEBELACHSE	PERNO PALANCA FRENO
	33	62ND15506	1	ROSETTA	WASHER	RONDELLE	UNTERLEGSCHIEBE	ARANDELA

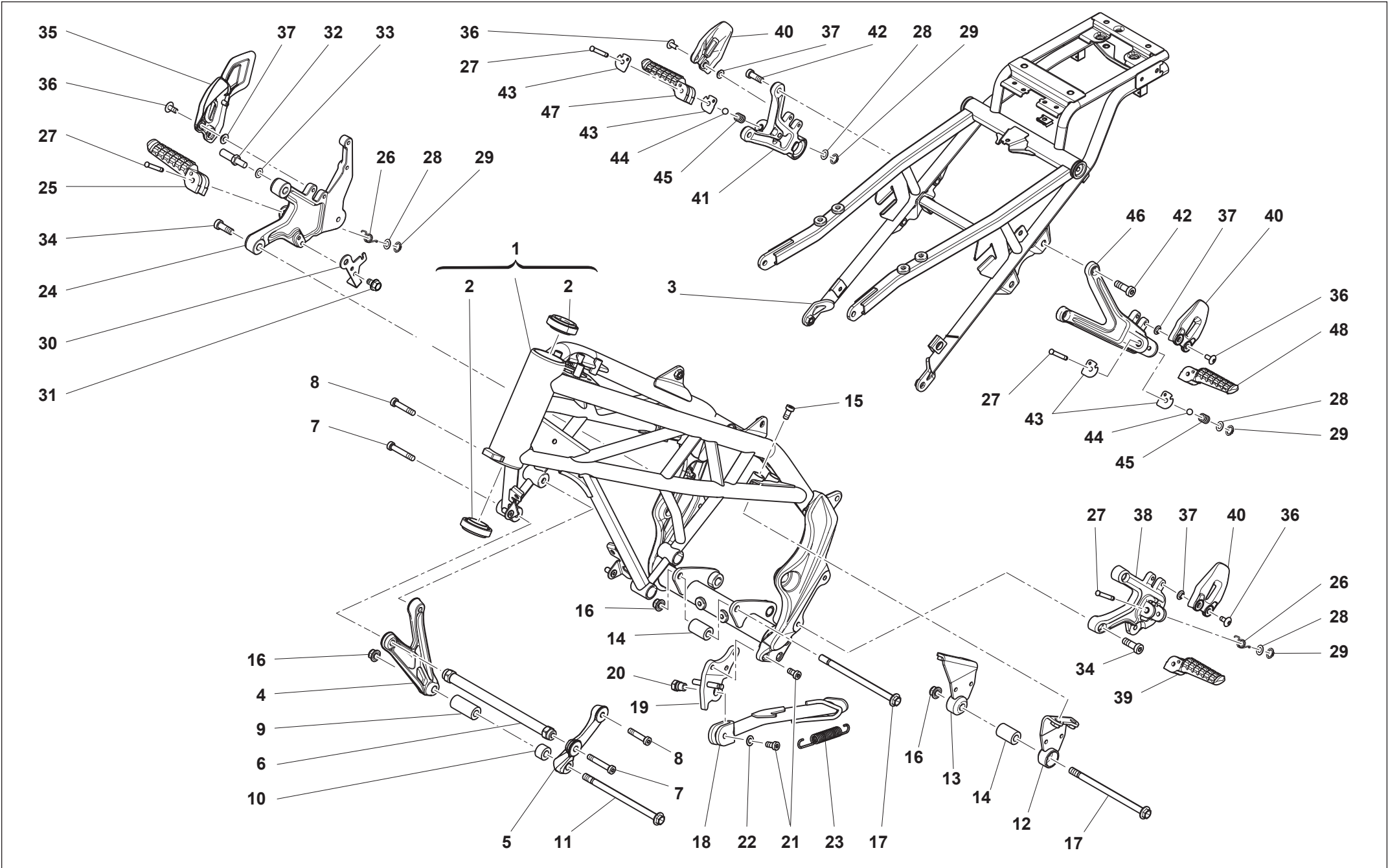

Note Notes Notes Marke Notas	Pos. No. N. Index Pos.	N. Cod. Code No. Nr. Code Code Nr N. Cod.	Q.tà Q.ty Q.te M.ge C.ad	DENOMINAZIONE	NAME	DESIGNATION	BESHREIBUNG	DENOMINACION
	34	FB00P03798	4	VITE TCEI RIBASSATA M8x25	NARROW SCREW TCEI M8x25	VIS TCEI SURBAISSÉE M8x25	ABGEFL. ZYL.K.SCHRAUBE M. INNENSECHSK. M8x25	TORNILLO TCEI BAJO M8x25
	35	F000P03379	1	PARATACCO PEDANA DX	RH FOOTREST HEEL GUARD	PARE-TALON REPOSE-PIEDS DRT	FERSENSCHUTZ FUSSRASTE RECHTS	PROTECTOR TALÓN ESTRIBO DER.
	36	FB00P03820	8	VITE TBEI M6x14	BOLT TBEI M6x14	VIS TBEI M6x14	SCHRAUBE TBEI M6x14	TORNILLO TBEI M6x14
	37	8000H3017	8	BUSSOLA	BUSHING	DOUILLE	BUCHSE	CASQUILLO
	38	F000P03040	1	SUPPORTO PEDANA SINISTRA	L.H. FOOTREST SUPPORT	SUPPORT REPOSE-PIEDS GAUCHE	HALTERUNG FUßRASTE LINKS	SOPORTE ESTRIBO IZQUIERDA
	39	80A062563	1	PEDANA SINISTRA	L.H. FOOTREST	REPOSE-PIEDS GAUCHE	FUßRASTE LINKS	ESTRIBO IZQUIERDA
	40	F000P03380	3	PARATACCO PEDANA	FOOTREST HEEL GUARD	PARE-TALON REPOSE-PIEDS	FERSENSCHUTZ FUSSRASTE	PROTECTOR TALÓN ESTRIBO
	41	F000P03464	1	SUPPORTO PEDANA PASSEGGERO DX	PASSENGER RH FOOTREST SUPPORT	SUPPORT REPOSE-PIEDS PASSAGER DRT	HALTER BEIFAHRERFUSSRASTE RECHTS	SOPORTE ESTRIBO PASAJERO DER.
	42	FA00P03798	4	VITE TCEI RIBASSATA M8x16	NARROW SCREW TCEI M8x16	VIS TCEI SURBAISSÉE M8x16	ABGEFL. ZYL.K.SCHRAUBE M. INNENSECHSK. M8x16	TORNILLO TCEI BAJO M8x16
	43	F000P03574	4	PIASTRINA PEDANA POSTERIORE	REAR FOOTREST PLATE	PLATINE REPOSE-PIEDS ARRIÈRE	PLÄTTCHEN HINTERE FUSSRASTE	PLACA ESTRIBO TRASERO
	44	6BN021507	2	SFERA	BALL	BILLE	KUGEL	BOLA
	45	800062655	2	MOLLA	SPRING	RESSORT	FEDER	MUELLE
	46	F000P03465	1	SUPPORTO PEDANA PASSEGGERO SX	PASSENGER LH FOOTREST SUPPORT	SUPPORT REPOSE-PIEDS PASSAGER GCHE	HALTER BEIFAHRERFUSSRASTE LINKS	SOPORTE ESTRIBO PASAJERO IZQ.
	47	8AA062562	1	PEDANA PASSEGGERO DESTRA	PASSENGER R.H. FOOTREST	REPOSE-PIEDS DROIT	FUßRASTE RECHTS	ESTRIBO DERECHA
	48	8AA062563	1	PEDANA PASSEGGERO SINISTRA	PASSENGER L.H. FOOTREST	REPOSE-PIEDS GAUCHE	FUßRASTE LINKS	ESTRIBO IZQUIERDA

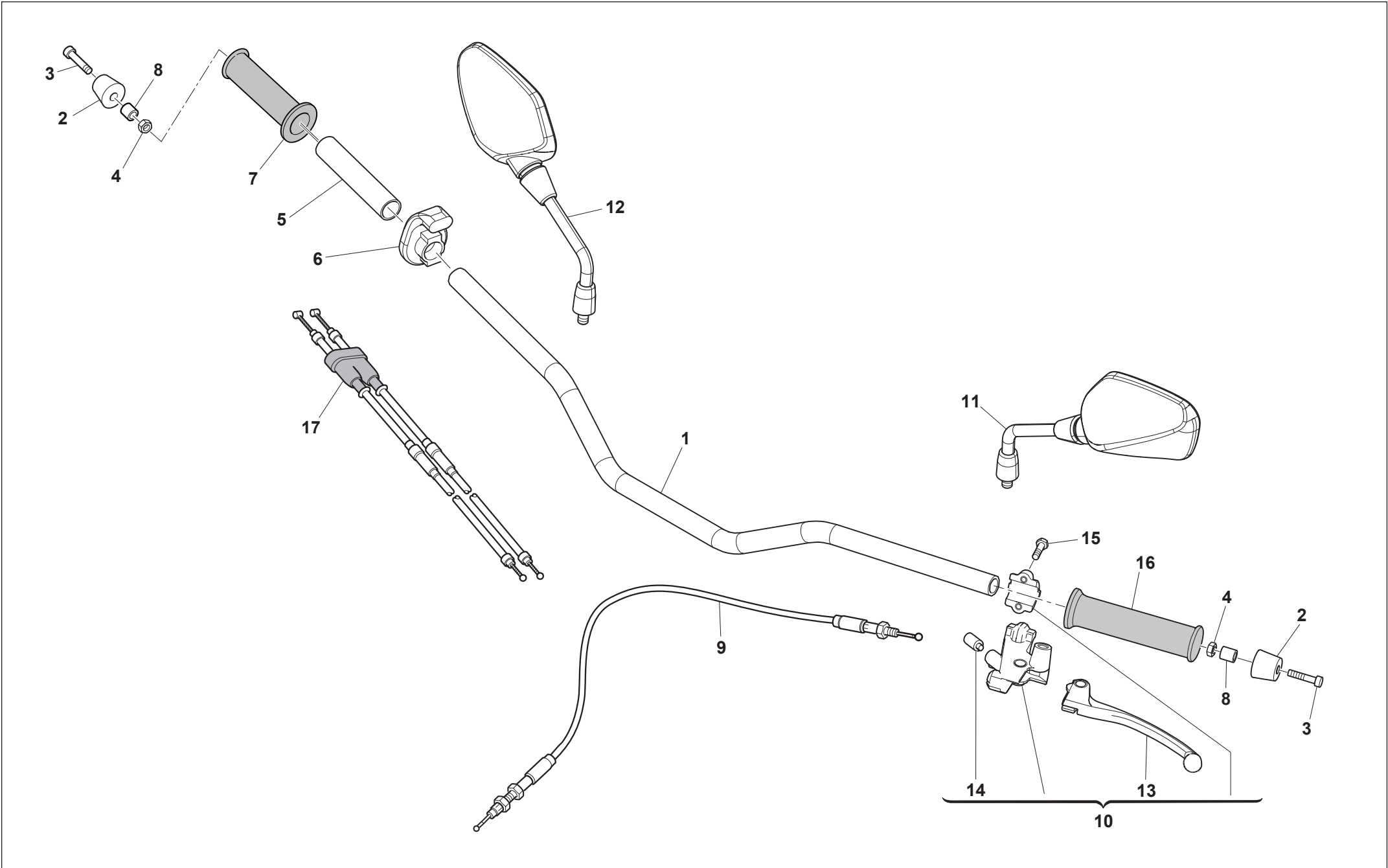

Note Notes Notes Marke Notas	Pos. No. Index Pos.	N. Cod. Code No. Nr. Code Code Nr. N. Cod.	Q.tà Q.ty Q.te M.ge C.ad	DENOMINAZIONE	NAME	DESIGNATION	BESHREIBUNG	DENOMINACION
	1	F000P02814	1	MANUBRIO	HANDLEBAR	GUIDON	LENKER	MANILLAR
	2	F000P03133	2	CONTRAPPESO	COUNTERBALANCE	CONTREPOIDS	GEGENGEWICHT	CONTRAPESO
	3	60ND02519	2	VITE TEI M6x70	BOLT TEI M6x70	VIS TEI M6x70	SCHRAUBE TEI M6x70	TORNILLO TEI M6x70
	4	61ND15062	2	DADO M6x1	NUT M6x1	ECROU M6x1	MUTTER M6x1	TUERCA M6x1
	5	F000P01640	1	TUBO COMANDO GAS	THROTTLE CONTROL TUBE	TUYAU COMMANDE GAZ	GASZUG	TUBO MANDO ACELERADOR
	6	F000A02010	1	ASSIEME SUPPORTO GAS	THROTTLE SUPPORT ASSY	ENSEMBLE SUPPORT GAZ	EINHEIT GASGRIFFHALTER	CONJUNTO SOPORTE ACELERADOR
	7	F000P02815	1	MANOPOLA DESTRA	RH HANDGRIP	POIGNÉE DROITE	GRIFF RECHTS	PUÑO DERECHA
	8	FD00P03206	2	TUBETTO	TUBE SPACER	TUYAU	ROHR	TUBO
	9	F000P02817	1	CAVO COMANDO FRIZIONE	CLUTCH CABLE	CÂBLE	KABEL	CABLE
	10	F000A03853	1	ASSIEME COMANDO FRIZIONE	CLUTCH CONTROL ASSY	COMMANDE EMBRAYAGE COMPL.	ZUSAMMENBAU KUPPLUNGSZUG	CONJUNTO MANDO EMBRAGUE
	11	F000P03074	1	SPECCHIETTO RETROV. SX	L.H. REAR-VIEW MIRROR	RÉTROVISEUR GAUCHE	RÜCKSPIEGEL LINKE	ESPEJO RETROV. IZQ.
	12	F000P03073	1	SPECCHIETTO RETROV. DX	R.H. REAR-VIEW MIRROR	RÉTROVISEUR DROITE	RÜCKSPIEGEL RECHTS	ESPEJO RETROV. DER.
	13	F000P03856	1	LEVA FRIZIONE	CLUTCH LEVER	LEVIER EMBRAYAGE	KUPPLUNGHEBEL	PALANCA EMBRAGUE
	14	45530027	1	INTERRUTTORE LEVA FRIZIONE	CLUTCH LEVER SWITCH	INTER. LEVIER EMBRAYAGE	KUPPLUNGSSCHALTER	INTER.PALANCAEMBRAGUE
	15	Z00062728	2	VITE TEF M6x20	FLANGED EXAGON HEAD SCREW M6x20	BOULON DE BRIDE M6x20	SCHRAUBE M6x20	TORNILLO M6x20
	16	F000P02816	2	MANOPOLA SINISTRA	L.H. HANDGRIP	POIGNÉE GAUCHE	GRIFF LINKS	PUÑO IZQUIERDA
	17	F000A03041	1	CAVO ACCELERATORE	CABLE ASSY, THROTTLE	CÂBLE COMMANDE DES GAZ	KABEL GASZUG	CABLE ACELERADOR

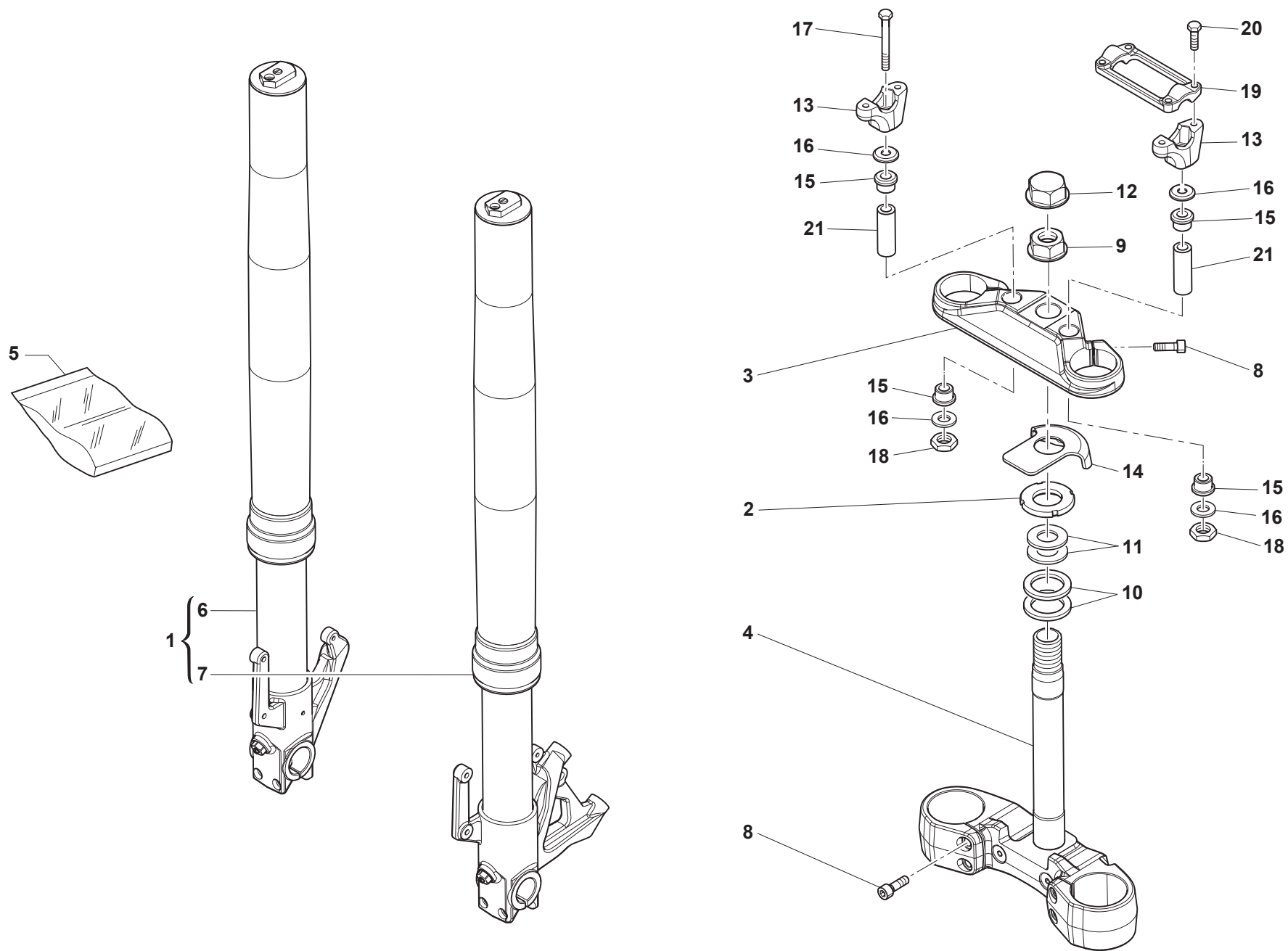

SOSPENSIONE ANTERIORE - FRONT FORK ASSEMBLY
SUSPENSION AVANT - VORDERTELESKOPGABEL
SUSPENSION DELANTERA

Note Notes Notes Marke Notas	Pos. No. N. Index Pos.	N. Cod. Code No. Nr. Code Code Nr N. Cod.	Q.tà Q.ty Q.te M.ge C.ad	DENOMINAZIONE	NAME	DESIGNATION	BESHREIBUNG	DENOMINACION
	1	F000A03498	1	ASSIEME GAMBE FORCELLA	FORK LEGS ASSY	ENSEMBLE FOURCHE	GABELGRUPPE	GRUPO HORQUILLA
	2	8A0087717	1	GHIERA PER PERNO DI STERZO	RING NUT	BAGUE	GEWINDERING	TUERCA ANULAR
	3	FA00P03045	1	TESTA DI STERZO	STEERING HEAD	TETE DE DIRECTION	LENKKOPF	CABEZAL DE DIRECCIÓN
	4	FA00A03046	1	BASE DI STERZO CON PERNO	BOTTOM YOKE WITH PIN	BASE DE DIRECTION AVEC AXE	LENKLAGER MIT BOLZEN	BASE DE DIRECCIÓN CON EJE
	5	F000P03641	2	GRUPPO PARAPOLVERE PARAOLI	OIL SEAL & DUST SEAL SET	ENS. PARE-POUSS. JOINTS PARE-HUILE	EINHEIT STAUBSTREIFER ÖLABDICHTUNGEN	GRUPO JUNTA ANTIPOLVO RETÉN DE ACEITE
	6	F000A03632	1	GAMBA DESTRA COMPLETA	COMPLETE R.H. SHOCK ABSORBER	BRANCHE DROITE COMPLÈTE	FEDERBEIN RECHTS KOMPLETT	PATA DER. COMPLETA
	7	F000A03633	1	GAMBA SINISTRA COMPLETA	COMPLETE L.H. SHOCK ABSORBER	BRANCHE GAUCHE COMPLÈTE	FEDERBEIN LINKE KOMPLETT	PATA IZQ. COMPLETA
	8	FB00P03798	6	VITE TCEI M8x25	SCREW TCEI M8x25	VIS TCEI M8x25	SCHRAUBE TCEI M8x25	TORNILLO TCEI M8x25
	9	8A0069315	1	DADO M26	NUT M26	ECROU M26	MUTTER M26	TUERCA M26
	10	800087736	2	ROSETTA	WASHER	RONDELLE	UNTERLEGSSCHEIBE	ARANDELA
	11	800087745	2	GUARNIZIONE	GASKET	JOINT	DICHTUNG	JUNTA
	12	F000P00912	1	TAPPO	PLUG	BOUCHON	STOPFEN	TAPON
	13	8000H2355	2	MORSETTO INFERIORE MANUBRIO	LOWER CLAMP	ETRIER INFERIEUR	KLEMME UNTEN	BORNE INFERIOR
	14	F000P03589	1	PIASTRINA BLOCCASTERZO	STEERING LOCK PLATE	PLATINE BLOCAGE DE DIRECTION	LENKERSPERRPLÄTTCHEN	PLACA BLOQUEO DIRECCIÓN
	15	800060233	4	SILENTBLOCK	SILENTBLOCK	SILENTBLOCK	SILENTBLOCK	SILENTBLOCK
	16	800060234	4	ROSETTA	WASHER	RONDELLE	UNTERLEGSSCHEIBE	ARANDELA
	17	60ND01219	2	VITE TE M10x65	FLANGED EXAGON HEAD SCREW M10x65	BOULON DE BRIDE M10x65	FLANSCHENSCHRAUBE M10x65	TORNILLO DE REBORDE M10x65
	18	Z00061314	2	DADO AUTOBLOCCANTE M10x1,5	SELF-LOCKING NUT M10x1,5	ECROU AUTOBLOQUANT M10x1,5	SELBSTSICHERNDE MUTTER M10x1,5	TUERCA AUTOBLOCANTE M10x1,5
	19	8000B0522	1	MORSETTO SUPERIORE MANUBRIO	UPPER CLAMP	ETRIER SUPERIEUR	KLEMME OBEN	BORNE SUPERIOR
	20	8A00B1959	4	VITE TEF M8x1,25x30	FLANGED EXAGON HEAD SCREW M8x1,25x30	BOULON DE BRIDE M8x1,25x30	FLANSCHENSCHRAUBE M8x1,25x30	TORNILLO DE REBORDEM8x1,25x30
	21	8000H3016	2	DISTANZIALE	SPACER	ENTRETOISE	ABSTANDHALTER	DISTANCIADOR

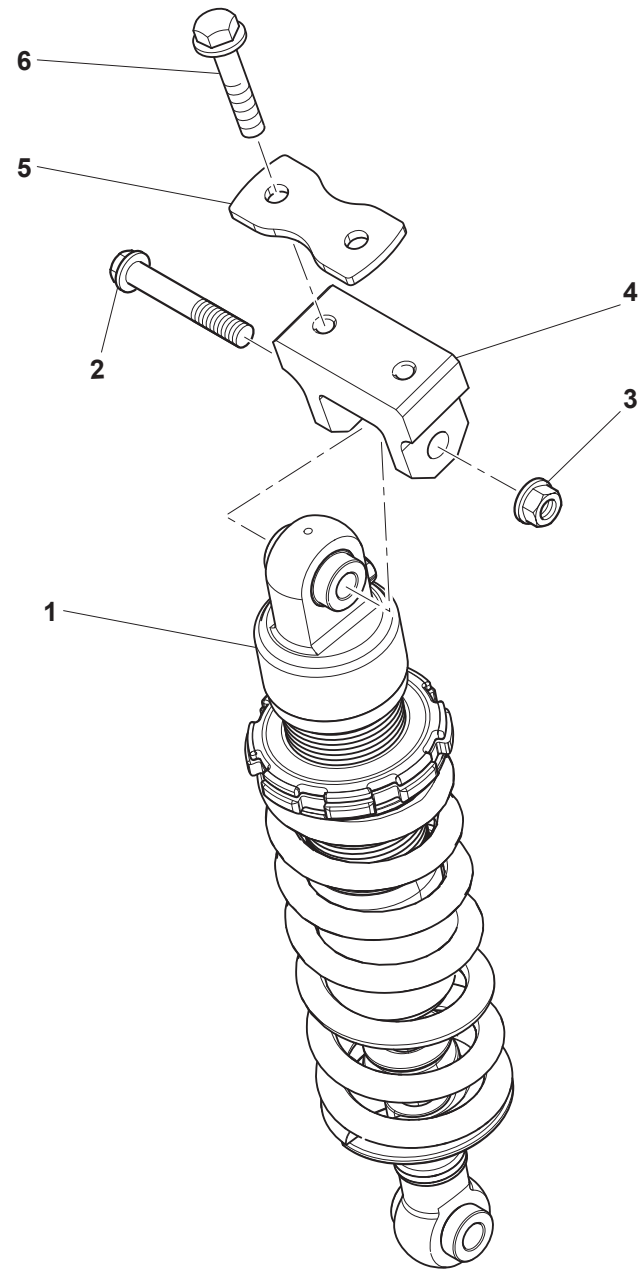

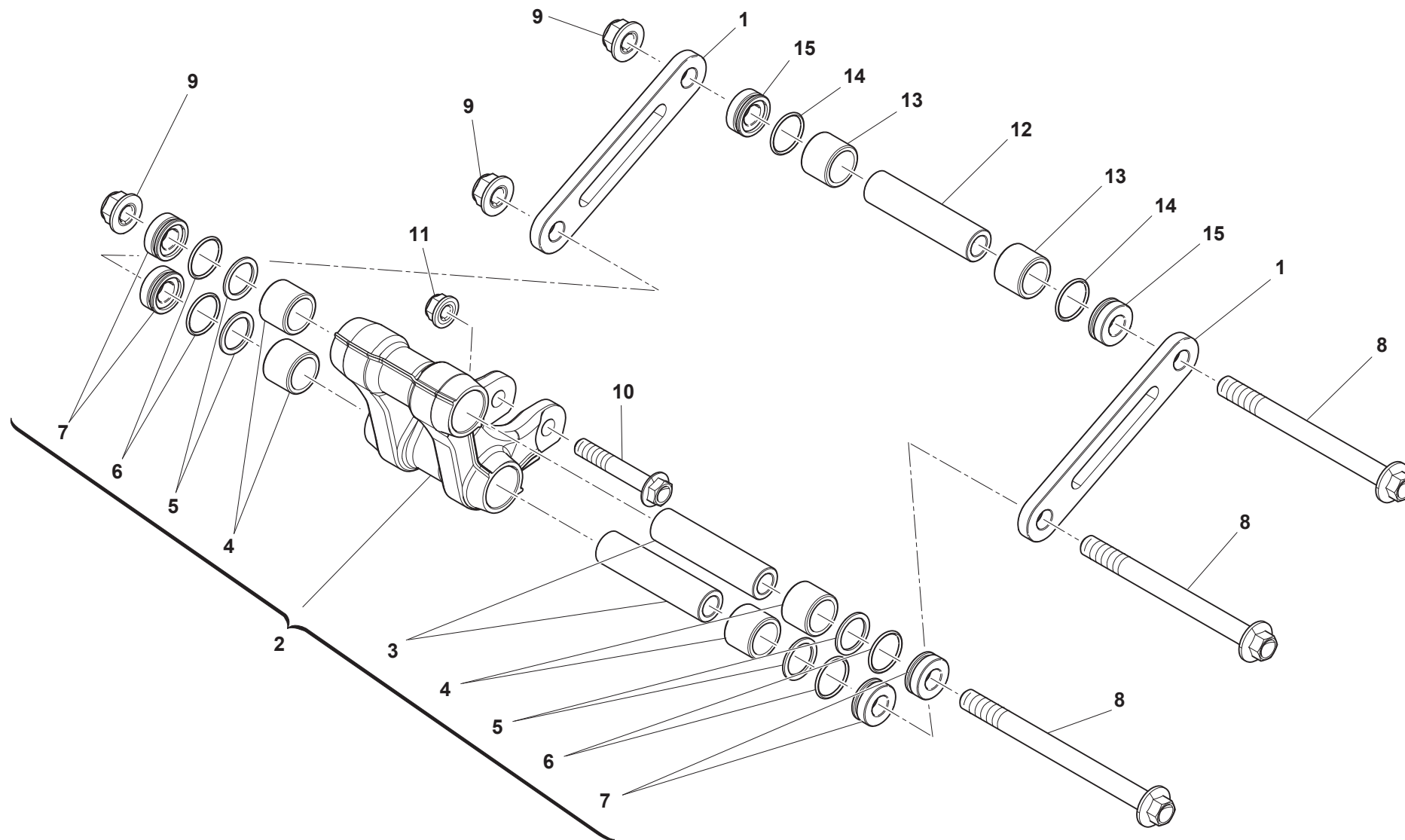

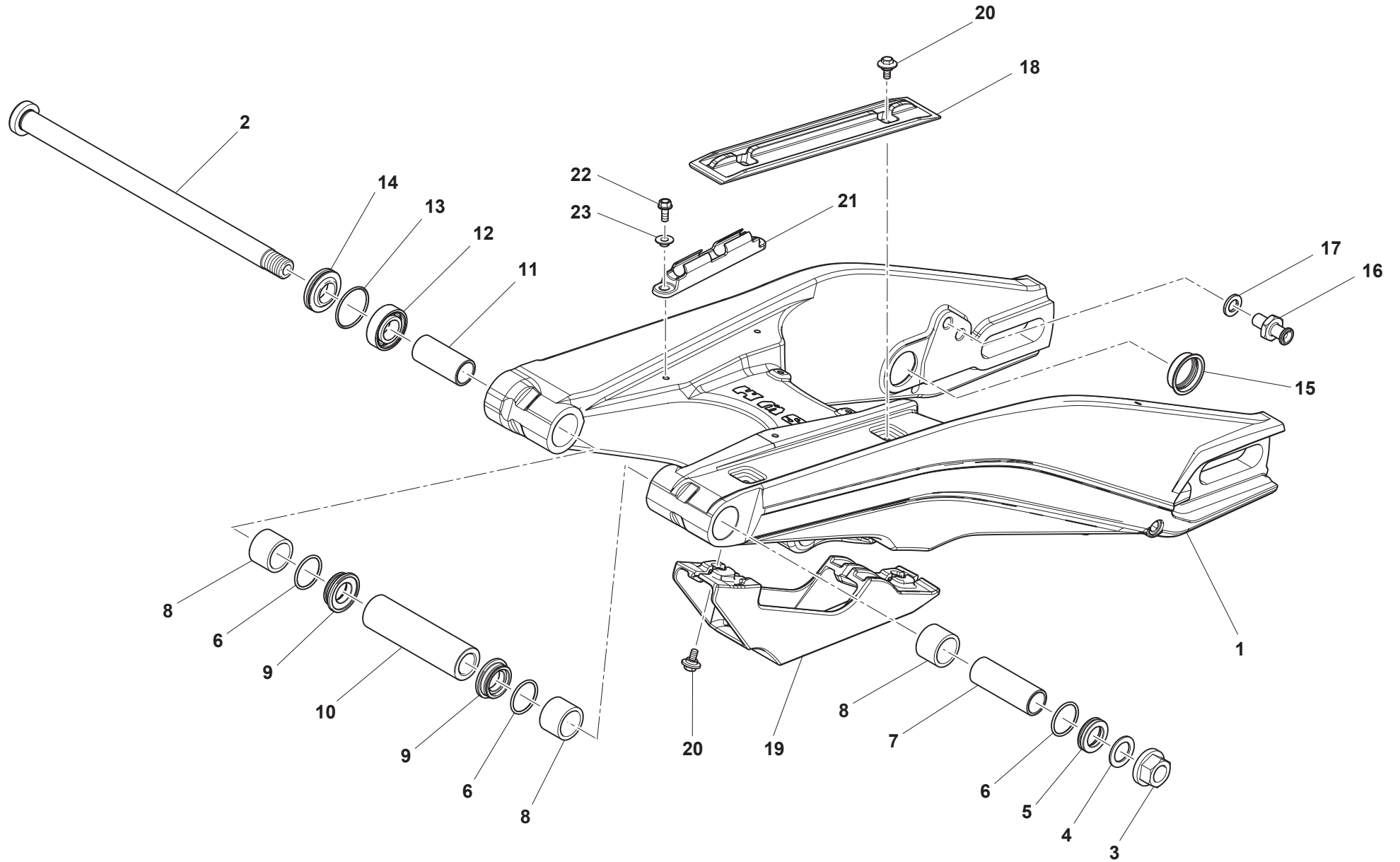

FORCELLONE POSTERIORE - REAR SWING ARM
FOURCHE ARRIERE - HINTERGABEL
HORQUILLA TRASERA

Note Notes Notes Marke Notas	Pos. No. N. Index Pos.	N. Cod. Code No. Nr. Code Code Nr N. Cod.	Q.tà Q.ty Q.te M.ge C.ad	DENOMINAZIONE	NAME	DESIGNATION	BESHREIBUNG	DENOMINACION
	1	F0A0P02825	1	FORCELLONE COMPLETO	COMPLETE SWINGING ARM	BRAS OSCILLANT COMPLET	SCHWINGE KOMPLETT	BASCULANTE COMPLETO
	2	F000P02933	1	PERNO FORCELLONE	SWINGING ARM PIN	AXE BRAS OSCILLANT	BOLZEN SCHWINGE	EJE BASCULANTE
	3	Z00071623	1	DADO FLANGIATO M16	FLANGED NUT M16	ECROU BRIDE M16	FLANSCHMUTTER M16	TUERCA CON BRIDA M16
	4	800032388	1	ROSETTA	WASHER	RONDELLE	UNTERLEGSCHIEBE	ARANDELA
	5	F000P03082	1	DISTANZIALE	SPACER	ENTRETOISE	ABSTANDHALTER	DISTANCIADOR
	6	F000P04343	3	ANELLO OR	O-RING	JOINT TORIQUE	O-RING	JUNTA TORICA
	7	F000P03593	1	SPINOTTO FORCELLONE SX	LH SWINGING ARM SHAFT	GOUJON BRAS OSCILLANT GCHE	LINKE HÜLSE FÜR SCHWINGE	EJE DE PISTÓN BASCULANTE IZQ.
	8	8000A4427	3	ASTUCCIO A RULLINI	NEEDLE ROLLER BEARING	CAGE À ROULEAUX	NADELBUCHSE	JAULA DE AGUJAS
	9	F000P03596	2	DISTANZIALE	SPACER	ENTRETOISE	ABSTANDHALTER	DISTANCIADOR
	10	F000P03595	1	DISTANZIALE INTERNO FORCELLONE	SWINGING ARM INNER SPACER	ENTRETOISE INTÉRIEURE BRAS OSCILLANT	INTERNES DISTANZSTÜCK HINTERRADSWINGE	DISTANCIADOR INTERNO BASCULANTE
	11	F000P03594	1	SPINOTTO FORCELLONE DX	RH SWINGING ARM SHAFT	GOUJON BRAS OSCILLANT DRT	RECHTE HÜLSE FÜR SCHWINGE	EJE DE PISTÓN BASCULANTE DER.
	12	F000P03048	1	CUSCINETTO 6003	BEARING 6003	ROULEMENT 6003	LAGER 6003	COJINETE 6003
	13	800040007	1	ANELLO OR	O-RING	JOINT TORIQUE	O-RING	JUNTA TORICA
	14	F000P03083	1	DISTANZIALE	SPACER	ENTRETOISE	ABSTANDHALTER	DISTANCIADOR
	15	FA00P03813	2	TAPPO	PLUG	BOUCHON	STOPFEN	TAPON
	16	F000P03543	1	VITE REAZIONE	REACTION SCREW	CONTRE-VIS	KONTERSCHRAUBE	TORNILLO REACCIÓN
	17	62ND15507	1	ROSETTA	WASHER	RONDELLE	UNTERLEGSCHIEBE	ARANDELA
	18	F000P02934	1	PATTINO CATENA SUPERIORE	UPPER CHAIN SLIDING SHOE	PATIN DE CHAÎNE SUPÉRIEUR	OBERE KETTENGLEITSCHIENE	PATÍN CADENA SUPERIOR
	19	F000P03466	1	PATTINO CATENA INFERIORE	LOWER CHAIN SLIDING SHOE	PATIN DE CHAÎNE INFÉRIEUR	UNTERE KETTENGLEITSCHIENE	PATÍN CADENA INFERIOR
	20	8000A8421	4	VITE TE M5x8	SCREW TE M5x8	VIS TE M5x8	SCHRAUBE TE M5x8	TORNILLO TE M5x8
	21	8000B1166	1	PASSATUBO FRENO POSTERIORE	REAR BRAKE HOSE RING	PASSE-TUBE DE FREIN ARRIERE	LEITUNGSDURCHFÜHRUNG HINTERRADBREMSE	PASATUBO FRENO TRASERO
	22	Z00067997	2	VITE TEF M5x12	FLANGED EXAGON HEAD SCREW M5x12	BOULON DE BRIDE M5x12	FLANSCHENSCHRAUBE M5x12	TORNILLO DE REBORDE M5x12
	23	800069282	2	BUSSOLA Ø14xØ7xØ5,25	BUSHING Ø14xØ7xØ5,25	DOUILLE Ø14xØ7xØ5,25	BUCHSE Ø14xØ7xØ5,25	CASQUILLO Ø14xØ7xØ5,25

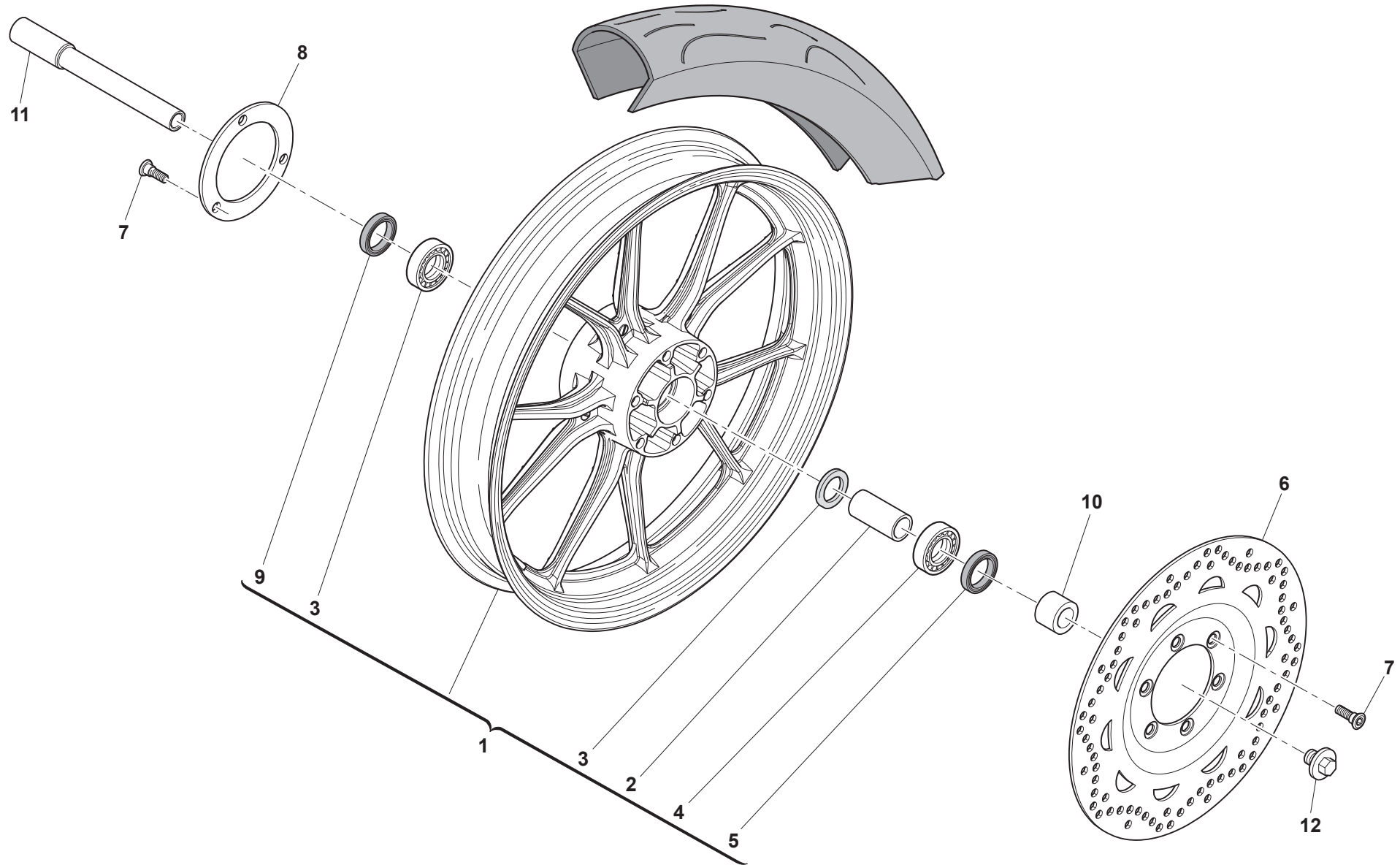

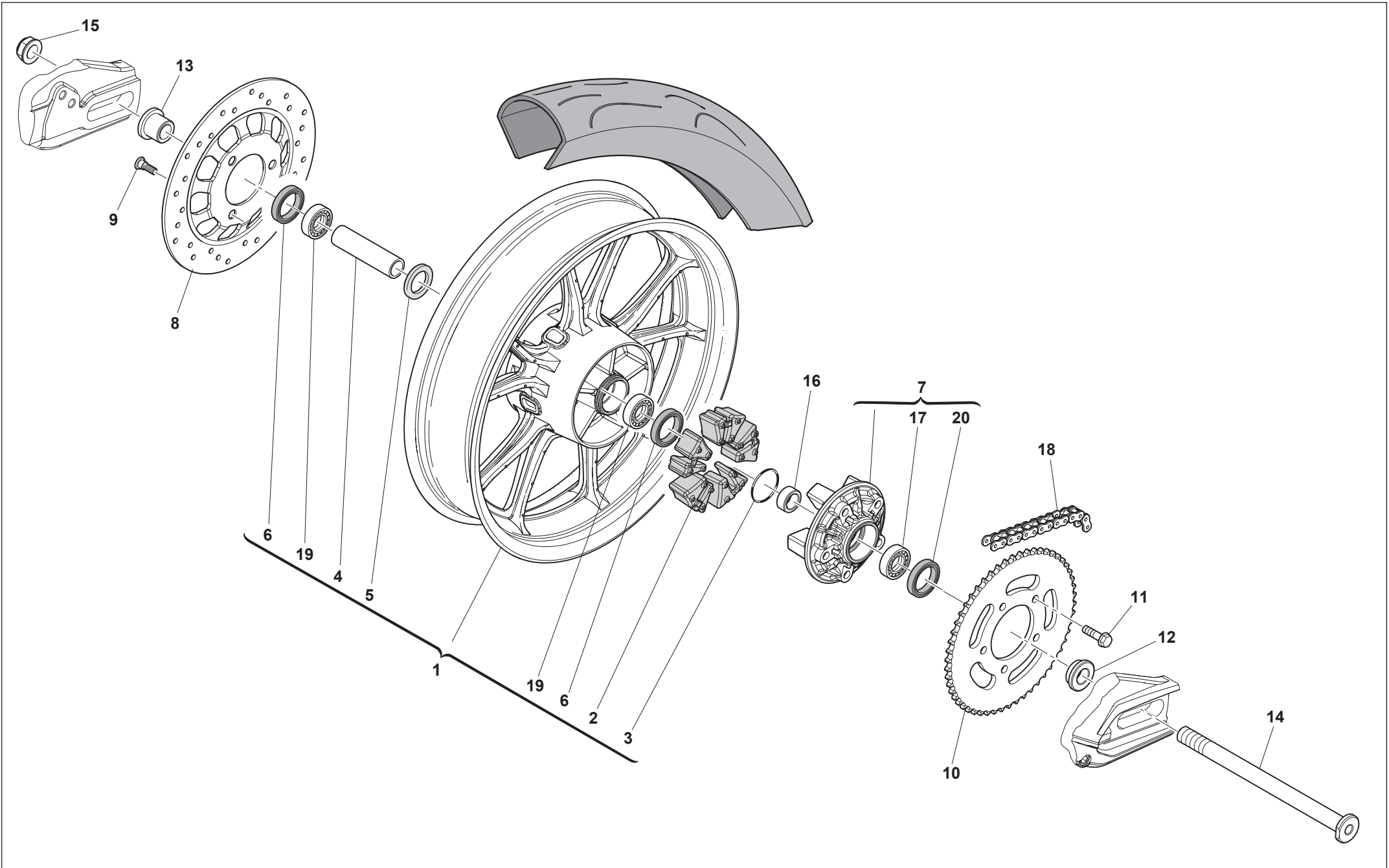

**RUOTA POSTERIORE - REAR WHEEL
ROUE ARRIERE - HINTERRAD
RUEDA TRASERA**

Note Notes Notes Marke Notas	Pos. No. N. Index Pos.	N. Cod. Code No. Nr. Code Code Nr N. Cod.	Q.tà Q.ty Q.te M.ge C.ad	DENOMINAZIONE	NAME	DESIGNATION	BESHREIBUNG	DENOMINACION
WHITE	1	F0A0A01606	1	RUOTA POSTERIORE SENZA PNEUMATICO	REAR WHEEL WITHOUT TYRE	ROUE ARRIERE SANS PNEU	HINTERRAD OHNE TYRE	RUEDA TRASERA SIN NEUMÁTICO
BLACK	1	F0B0A01606	1	RUOTA POSTERIORE SENZA PNEUMATICO	REAR WHEEL WITHOUT TYRE	ROUE ARRIERE SANS PNEU	HINTERRAD OHNE TYRE	RUEDA TRASERA SIN NEUMÁTICO
	2	F000P01607	5	PARASTRAPPI	ANTI-VIBRATION BUFFERS	AMORTISSEUR DE COUPLE	REIßSCHUTZ	ACOPLAMIENTO ELÁSTICO
	3	F000P01608	1	ANELLO OR	O-RING	JOINT TORIQUE	O-RING	JUNTA TORICA
	4	F000P01609	1	DISTANZIALE INTERNO	INTERNAL SPACER	ENTRETOISE INTÉRIEUR	INTERNER ABSTANDHALTER	DISTANCIADOR INTERNO
	5	F000P01610	1	ANELLO DI SUPPORTO	SUPPORT RING	BAGUE DE SUPPORT	HALTERUNG RING	ANILLO DE SOPORTE
	6	F000P02035	2	PARAOLIO Ø42xØ30x7	OIL SEAL Ø42xØ30x7	JOINT PARE-HUILE Ø42xØ30x7	ÖLDICHTRING Ø42xØ30x7	RETÉN DE ACEITE Ø42xØ30x7
	7	F000P01612	1	ASSIEME SUPPORTO CORONA	SUPPORT SPROCKET ASSY	SUPPORT DE COURONNE COMPLET	ZAHNKRANZ HALTERUNG KOMPLETT	SOPORTE DE CORONA COMPLETO
	8	F000P01613	1	DISCO FRENO POSTERIORE	REAR BRAKE DISC	DISQUE DE FREIN	BREMSSSCHEIBE	DISCO FRENO
	9	72012198	3	VITE	BOLT	VIS	SCHRAUBE	TORNILLO
	10	F000P04133	1	CORONA DENTATA Z=53	CHAIN SPROCKET T=53	COURONNE DENTÉE D=53	ZAHNKRANZ Z=53	CORONA DENTADA Z=53
	11	ZF0062797	5	VITE FISSAGGIO CORONA M10x30	CHAIN CONNECT CLIP BOLT M10x30	VIS DE FIXATION COURONNE M10x30	BEFESTIGUNG SCHRAUBE ZAHNKRANZ M10x30	TORNILLO FIJACIÓN CORONA M10x30
	12	F000P03590	1	DISTANZIALE SINISTRO	LEFT SPACER	ENTRETOISE GAUCHE	ABSTANDHALTER LINKS	DISTANCIADOR IZQUIERDO
	13	F000P01615	1	DISTANZIALE DESTRO	RIGHT SPACER	ENTRETOISE DROIT	ABSTANDHALTER RECHTS	DISTANCIADOR DERECHO
	14	F000P03087	1	PERNO RUOTA	WHEEL AXLE	PIVOT DE ROUE	RADASCHE	EJE RUEDA
	15	Y00093072	1	DADO M20x1,5	NUT M20x1,5	ECROU M20x1,5	MUTTER M20x1,5	TUERCA M20x1,5
	16	F000P01611	1	DISTANZIALE	SPACER	ENTRETOISE	ABSTANDHALTER	DISTANCIADOR
	17	F000P02032	1	CUSCINETTO Ø47xØ20x14	BEARING Ø47xØ20x14	ROULEMENT Ø47xØ20x14	LAGER Ø47xØ20x14	COJINETE Ø47xØ20x14
	18	F000P02935	1	CATENA 138 MAGLIE	CHAIN, 138 PITCHES	CHAÎNE 138 MAILLONS	KETTE 138 GLIEDER	CADENA 138 ESLABONES
	19	F000P02031	2	CUSCINETTO Ø42xØ20x12	BEARING Ø42xØ20x12	ROULEMENT Ø42xØ20x12	LAGER Ø42xØ20x12	COJINETE Ø42xØ20x12
	20	F000P02065	1	PARAOLIO Ø42xØ30x7	OIL SEAL Ø42xØ30x7	JOINT PARE-HUILE Ø42xØ30x7	ÖLDICHTRING Ø42xØ30x7	RETÉN DE ACEITE Ø42xØ30x7

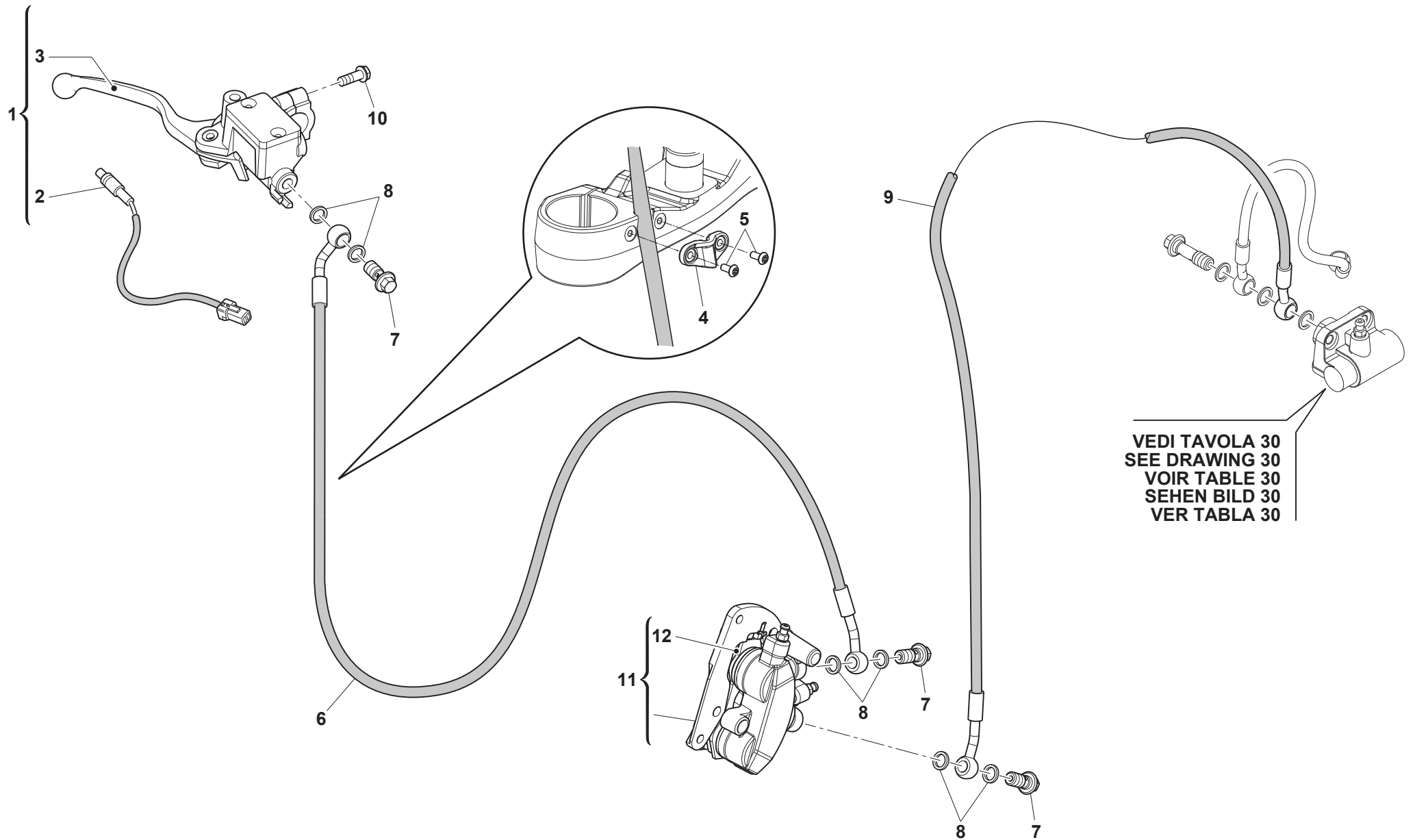



FRENO IDRAULICO ANTERIORE - FRONT HYDRAULIC BRAKE FREIN HYDRAULIQUE AVANT - VORDERBREMSE FRENO HIDRAULICO DELANTERO

Note Notes Notas	Pos. No. Index Pos.	N. Cod. Code No. Nr. Code Code Nr N. Cod.	Q.tà Q.ty M.ge C.ad	DENOMINAZIONE	NAME	DESIGNATION	BESHREIBUNG	DENOMINACION
	1	F000A01289	1	COMANDO FRENO ANTERIORE	FRONT BRAKE CONTROL	COMMANDE FREIN	BREMSZUG	MANDO FRENO
	2	F000P01620	1	INTERRUTTORE POMPA FRENO	FRONT BRAKE PUMP SWITCH	FIXATION	SCHALTER	INTERRUPTOR FRENO
	3	F000P01618	1	LEVA FRENO ANTERIORE	FRONT BRAKE LEVER	LEVIER	HEBEL	PALANCA
	4	F000P03792	1	GUIDA TUBI FRENO ANTERIORE	FRONT BRAKE HOSE GUIDE	GUIDE DURITES FREIN AVANT	FÜHRUNG VORDERE BREMSLEITUNGEN	GUÍA TUBOS FRENO DELANTERO
	5	F000P04013	2	VITE TBTX M5x12	SCREW TBTX M5x12	VIS TBTX M5x12	FLACHKOPFSCHRAUBE MIT INNENSECHSKANT M5x12	TORNILLO TBTX M5x12
	6	F000P02886	1	TUBO FRENO ANTERIORE	FRONT BRAKE HOSE	TUYAU DE FREIN AVANT	ROHR VORDERRADBREMSE	TUBO FRENO DELANTERO
	7	F000P02044	3	VITE TE M10x19	HEXAGON SOCKET-HEAD BOLT M10x19	VIS M10x19	SCHRAUBE M10x19	TORNILLO M10x19
	8	800021480	6	ROSETTA	WASHER	RONDELLE	UNTERLEGSCHNEIBE	ARANDELA
	9	F000P02924	1	TUBO PINZA FRENO - CBS	CBS - BRAKE CALLIPER PIPE	TUYAU ETRIER DE FREIN - CBS	ROHR BREMSSELTEL - CBS	TUBO PINZA FRENO - CBS
	10	Z00062727	2	VITE TEF M6x16	FLANGED EXAGON HEAD SCREW M6x16	BOULON DE BRIDE M6x16	FLANSCHENSCHRAUBE M6x16	TORNILLO DE REBORDE M6x16
	11	F000A01621	1	PINZA FRENO ANTERIORE	FRONT BRAKE CALLIPER	ETRIER DE FREIN AVANT	BREMSSELTEL VORDERR	PINZA FRENO DELANTERO
	12	F000P02030	1	COPPIA PASTIGLIE	PAIR OF BRAKE PADS	PAIRE PLAQUETTES	PAAR BREMSBELÄGE	PAREJA PASTILLAS

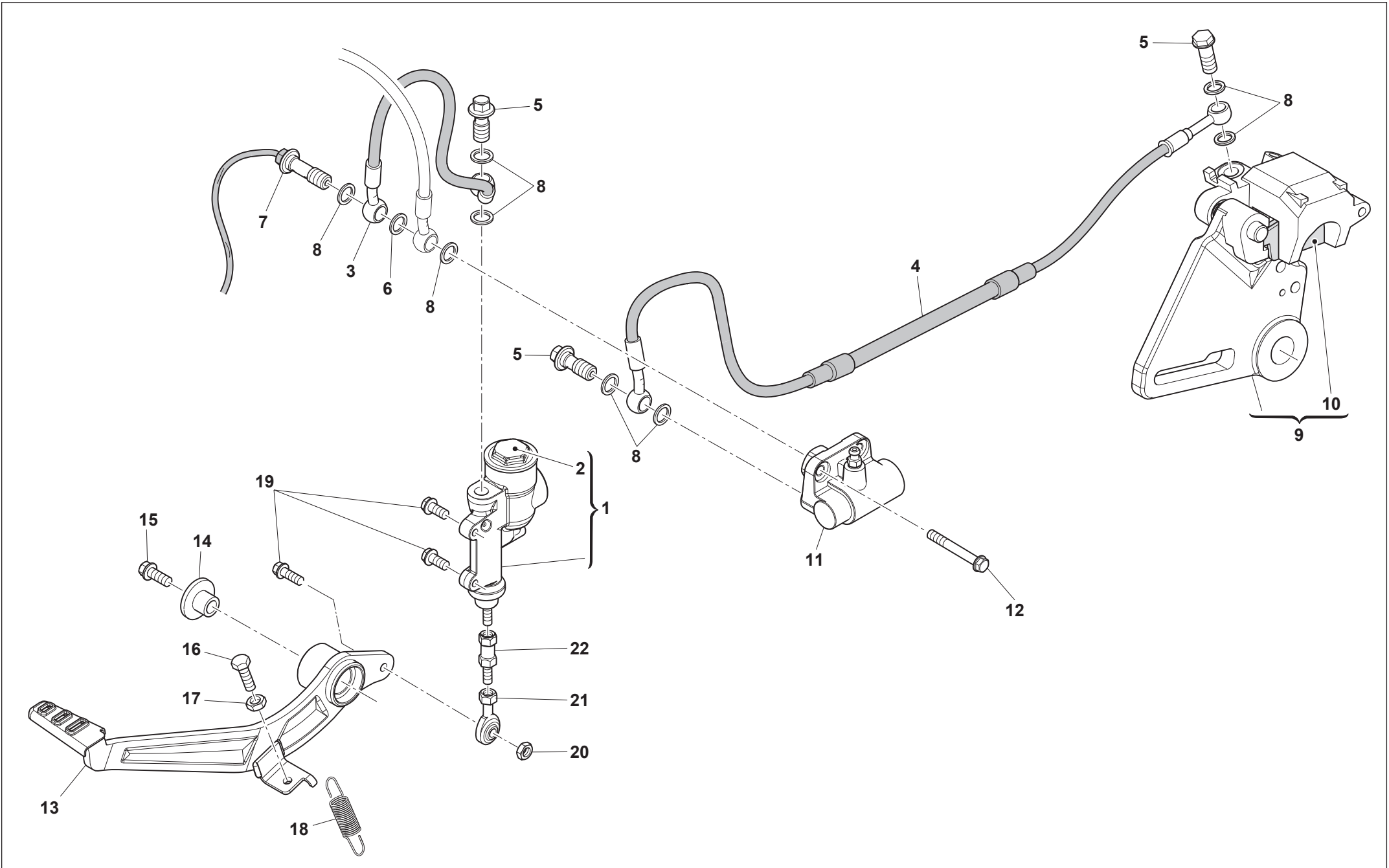

FRENO IDRAULICO POSTERIORE - REAR HYDRAULIC BRAKE
FREIN HYDRAULIQUE ARRIERE - HINTERBREMSE
FRENO HIDRAULICO TRASERO

Note Notes Marke Notas	Pos. No. Index Pos.	N. Cod. Code No. Nr. Code Code Nr N. Cod.	Q.tà Q.ty Q.te M.ge C.ad	DENOMINAZIONE	NAME	DESIGNATION	BESHREIBUNG	DENOMINACION
	1	FF000A01294	1	POMPA FRENO POSTERIORE	REAR BRAKE PUMP	MAÎTRE-CYLINDRE DE FREIN	ZUSAMMENBAU HAUPTBREMSZYLINDER	CONJUNTO BOMBA FRENO
	2	F000P02039	1	TAPPO SERBATOIO FRENO POSTERIORE	REAR BRAKE TANK CAP	BOUCHON RESERVOIR DE FREIN ARRIERE	TANKDECKEL HINTERRADBREMSE	TAPON DEPÓSITO FRENO TRASERO
	3	F000P02923	1	TUBO POMPA - CBS	CBS - PUMP PIPE	TUYAU POMPE - CBS	ROHR PUMPE - CBS	TUBO BOMBA - CBS
	4	F000P02925	1	TUBO PINZA FRENO - CBS	CBS - BRAKE CALLIPER PIPE	TUYAU ETRIER DE FREIN - CBS	ROHR BREMSSELTEL - CBS	TUBO PINZA FRENO - CBS
	5	F000P02044	3	VITE TE M10x19	HEXAGON SOCKET-HEAD BOLT M10x19	VIS M10x19	SCHRAUBE M10x19	TORNILLO M10x19
	6	800090485	1	ROSETTA	WASHER	RONDELLE	SCHRAUBE	TORNILLO
	7	F000P03920	1	INTERRUTTORE STOP POSTERIORE	REAR STOP SWITCH	INTERRUPTEUR STOP ARRIÈRE	BREMSLICHTSCHALTER	INTERRUPTOR FRENO TRASERO
	8	800021480	8	ROSETTA	WASHER	RONDELLE	UNTERLEGSCHIEBE	ARANDELA
	9	F000P01332	1	PINZA FRENO POSTERIORE	REAR BRAKE CALLIPER	ETRIER DE FREIN ARRIERE	BREMSELTEL HINT.	PINZA FRENO TRASERO
	10	F000P02029	1	COPIA PASTIGLIE	PAIR OF BRAKE PADS	PAIRE PLAQUETTES	PAAR BREMSBELÄGE	PAREJA PASTILLAS
	11	F000P01295	1	RIPARTITORE DI FRENATA CBS	DISTRIBUTION FRAME BRAKING	REPARTITEUR POUR LE FREINAGE	VERTEILER FÜR BREMSE	RED DE DISTRIBUCION PARA FRENADO
	12	Z00062731	1	VITE TEF M6x45	FLANGED EXAGON HEAD SCREW M6x45	BOULON DE BRIDE M6x45	FLANSCHENSCHRAUBE M6x45	TORNILLO DE REBORDE M6x45
	13	F000A00513	1	PEDALE COMANDO FRENO	BRAKE CONTROL PEDAL	PÉDALE COMMANDE DE FREIN	BREMSPEDAL	PEDAL MANDO FRENO
	14	70230006	1	BUSSOLA FLANGIATA	FLANGED BUSHING	DOUILLE A BRIDE	FLANSCHBUCHSE	CASQUILLO CON BRIDA
	15	60ND02505	1	VITE TEF M6x12	FLANGED EXAGON HEAD SCREW M6x12	BOULON DE BRIDE M6x12	FLANSCHENSCHRAUBE M6x12	TORNILLO DE REBORDE M6x12
	16	60ND01081	1	VITE TE M6x25	HEXAGON SOCKET-HEAD BOLT M6x25	VIS M6x25	SCHRAUBE M6x25	TORNILLO M6x25
	17	61ND15033	1	DADO M6	NUT M6	ECROU M6	MUTTER M6	TUERCA M6
	18	800055903	1	MOLLA PEDALE FRENO	RETURN SPRING	RESSORT	FEDER	MUELLE
	19	Z00062728	3	VITE TEF M6x16	FLANGED EXAGON HEAD SCREW M6x16	BOULON DE BRIDE M6x16	FLANSCHENSCHRAUBE M6x16	TORNILLO DE REBORDE M6x16
	20	61ND15062	1	DADO M6	NUT M6	ECROU M6	MUTTER M6	TUERCA M6
	21	8A0076055	1	SNODO SFERICO	BALL JOINT	ARTICULATION À ROTULE	KUGELGELENK	ARTICULACIÓN ESFÉRICA
	22	8000A7635	1	PUNTALINO	PIN	EMBOUT	AUFLAGESTIFT	TERMINAL

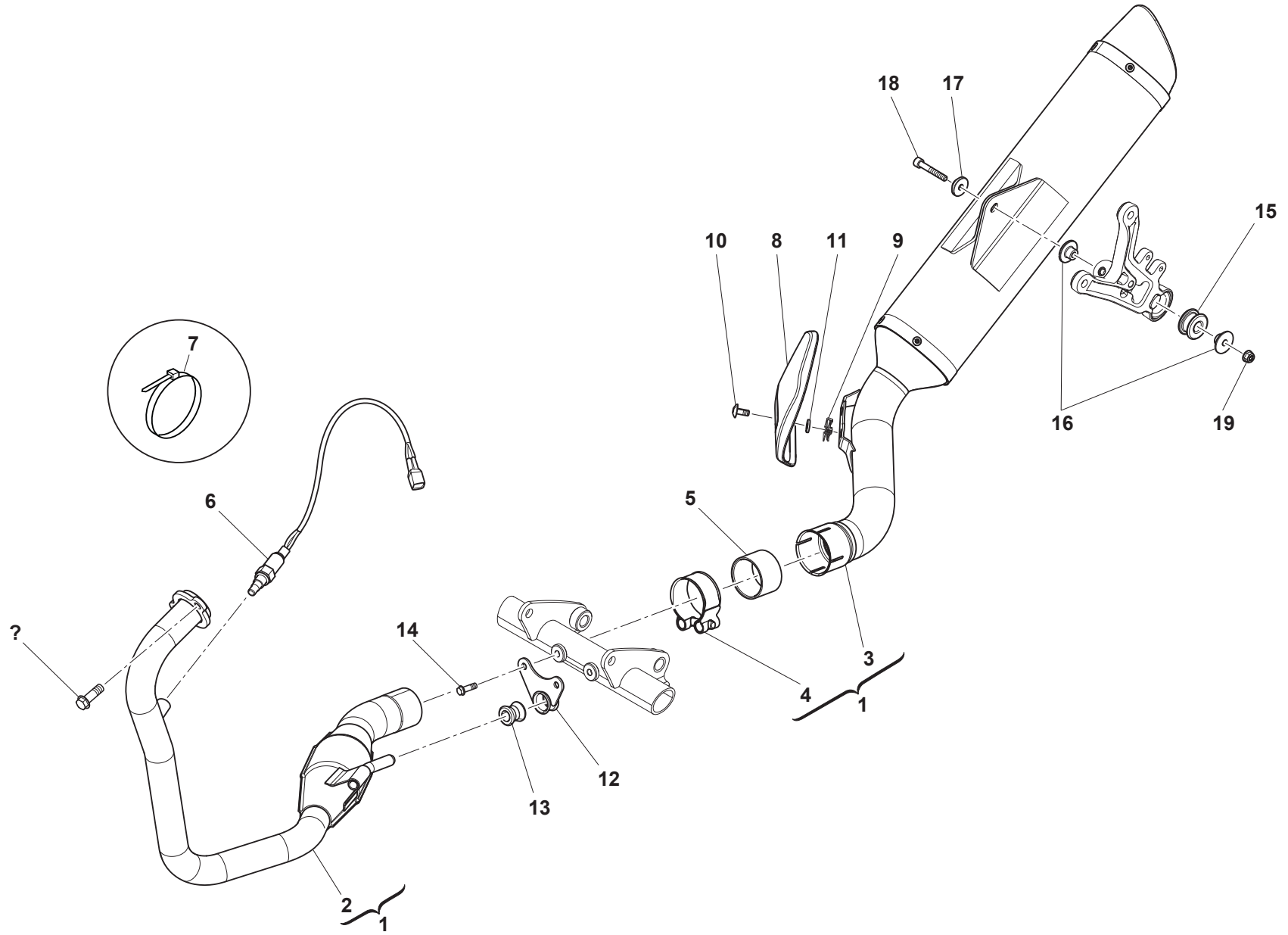

**SCARICO - EXHAUST SYSTEM
TUYAU D'ÉCHAPPEMENT - AUSPUFFROHR
TUBO DE ESCAPE**

TAVOLA
DRAWING
TABLE
BILD
TABLA

Note Notes Notes Marke Notas	Pos. No. Index Pos.	N. Cod. Code No. Nr. Code Code Nr N. Cod.	Q.tà Q.ty Q.te M.ge C.ad	DENOMINAZIONE	NAME	DESIGNATION	BESHREIBUNG	DENOMINACION
	1	F000A02926_P	1	ASS. IMPIANTO DI SCARICO	EXHAUST SYSTEM ASSY	INSTALLATION DE ECHAPPEMENT	AUSPUFFROHR KOMPLETT	EQUIPO DE ESCAPE
	2	F000P03089	1	TUBO DI SCARICO	EXHAUST PIPE	POT D'ÉCHAPPEMENT	AUSPUFFROHR	TUBO DE ESCAPE
	3	F000P03090	1	SILENZIATORE DI SCARICO	SILENCER	SILENCIEUX	SCHALLDÄMPFER	SILENCIADOR
	4	F000P03754	1	FASCETTA D50	CLAMP	COLLIER	SHELLE	ABRAZADERA
	5	F000P03772	1	GUARNIZIONE	GASKET	JOINT	DICHTUNG	JUNTA
	6	F000P00856	1	SONDA LAMBDA	LAMBDA SENSOR	SONDE LAMBDA	LAMBDA-SONDE	SONDA LAMBDA
	7	800056783	2	FASCETTA	CLAMP	COLLIER	SHELLE	ABRAZADERA
	8	F000P03843	1	PROTEZIONE CALORE SILENZIATORE	HEAT-PROTECTING COVER	PROTECTION CHALEUR	HITZESCHUTZ	PROTECCIÓN CALOR
	9	U00046893	2	DADO A GRAFFETTA M6	CLIP NUT M6	ECROU À AGRAFE M6	SICHERUNGSMUTTER M6	TUERCA DE CLIP M6
	10	FB00P03820	2	VITE TBEI M6x14	BOLT TBEI M6x14	VIS TBEI M6x14	SCHRAUBE TBEI M6x14	TORNILLO TBEI M6x14
	11	800035112	2	ROSETTA ISOLANTE	HEAT-PROTECTING WASHER	RONDELLE ANTI-CHALEUR	HITZESCHUTZSCHIEBE	ARANDELA ANTICALOR
	12	F000P03649	1	PIASTRA SUPPORTO SCARICO	EXHAUST PIPE SUPPORT PLATE	PLAQUE DE SUPPORT ÉCHAPPEMENT	AUSPUFFPLATTE	PLACA SOPORTE ESCAPE
	13	8000H0064	2	SILENT BLOCK	SILENT BLOCK	ANTIVIBRATION	SILENT BLOCK	SILENT BLOCK
	14	Z00062727	2	VITE TEF M6x16	FLANGED EXAGON HEAD SCREW M6x16	BOULON DE BRIDE M6x16	FLANSCHENSCHRAUBE M6x16	TORNILLO DE REBORDE M6x16
	15	800089302	1	ANTIVIBRANTE	SILENT-BLOCK	ANTIVIBRATION	SCHWINGUNGSDAMFER	ANTIVIBRADOR
	16	8000A7729	2	DISTANZIALE	SPACER	ENTRETOISE	ABSTANDHALTER	DISTANCIADOR
	17	8000A5678	1	ROSETTA	WASHER	RONDELLE	UNTERLEGSCHIEBE	ARANDELA
	18	60ND02513	1	VITE TCEI M6x40	SCREW TCEI M6x40	VIS TCEI M6x40	SCHRAUBE TCEI M6x40	TORNILLO TCEI M6x40
	19	Z00044240	1	DADO AUTOBLOCCANTE M6	SELF-LOCKING NUT M6	ECROU AUTOBLOQUANT M6	SELBSTSICHERNDE MUTTER M6	TUERCA AUTOBLOCANTE M6

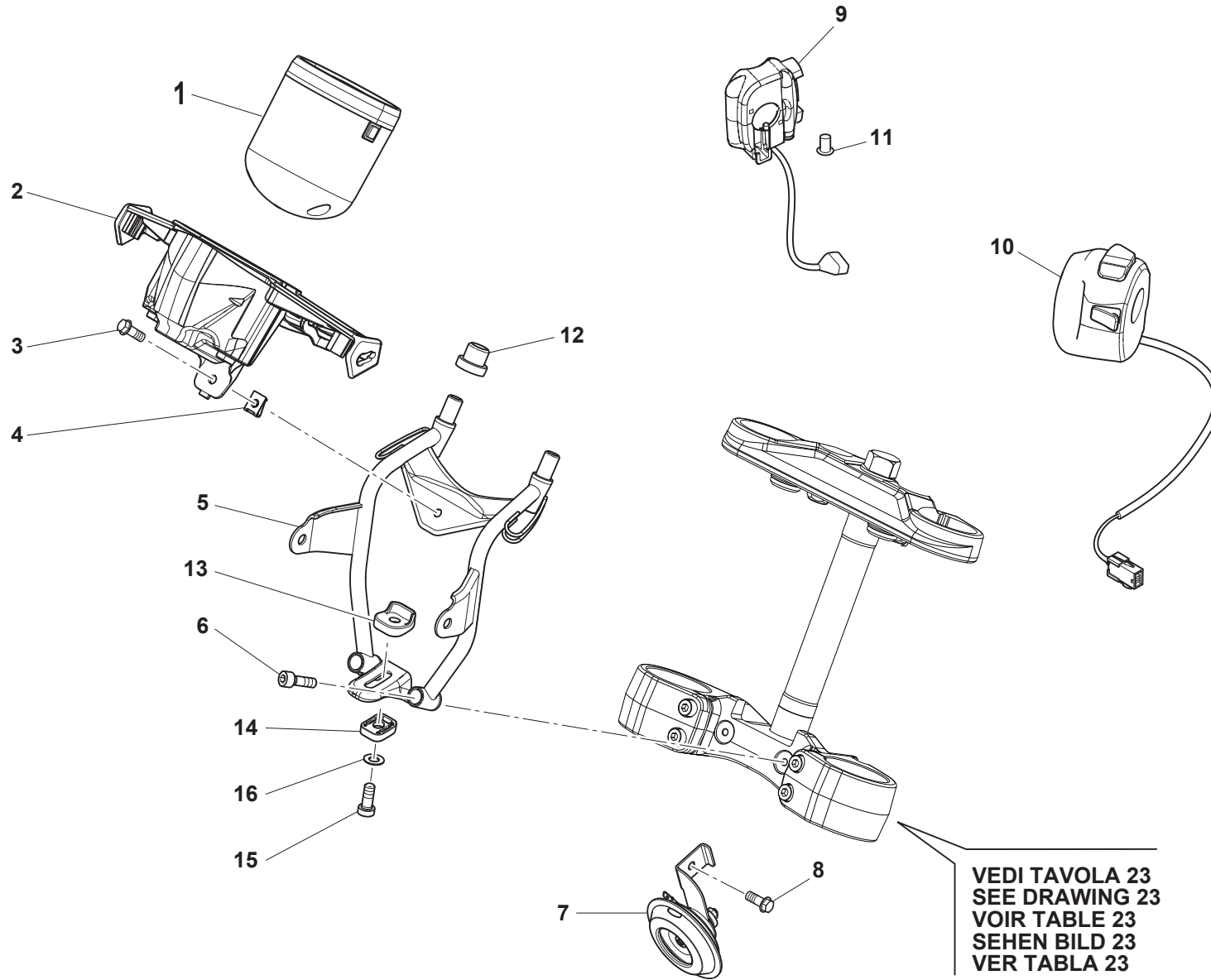

STRUMENTO DIGITALE - DIGITAL INSTRUMENT
INSTRUMENT DIGITAL - DIGITAL TACHOMETER
INSTRUMENTO DIGITAL

Note Notes Notas	Pos. No. Index Pos.	N. Cod. Code No. Nr. Code Code Nr N. Cod.	Q.tà Q.ty Q.te M.ge C.ad.	DENOMINAZIONE	NAME	DESIGNATION	BESHREIBUNG	DENOMINACION
	1	E000P03650	1	ASSIEME STRUMENTO	INSTRUMENT ASSY	INSTRUMENT ENSEMBLE	ZUSAMMENBAU INSTRUMENT	CONJUNTO INSTRUMENTO
	2	F000P03670	1	SUPPORTO CARENA	COVER SUPPORT	SUPPORT CARÉNAGE	VERKLEIDUNGSHALTER	SOPORTE CARENADO
	3	ZH0067545	1	VITE TEF M6x12	FLANGED EXAGON HEAD SCREW M6x12	BOULON DE BRIDE M6x12	FLANSCHENSCHRAUBE M6x12	TORNILLO DE REBORDE M6x12
	4	U00046893	1	DADO A GRAFFETTA M6	CLIP NUT M6	ECROU À AGRAFE M6	SICHERUNGSMUTTER M6	TUERCA DE CLIP M6
	5	F000A03585	1	TELAIO PORTA FARO	HEADLIGHT MOUNTING FRAME	CADRE PORTE-PHARE	SCHEINWERFERRAHMEN	ESTRUCTURA PORTAFARO
	6	60ND02505	2	VITE TCEI M6x12	SCREW TCEI M6x12	VIS TCEI M6x12	SCHRAUBE TCEI M6x12	TORNILLO TCEI M6x12
	7	E000A03791	1	AVVISATORE ACUSTICO	HORN	AVERTISSEUR SONORE	HUPE	AVISADOR ACÚSTICO
	8	ZH0067545	1	VITE M6x12	SCREW M6x12	VIS M6x12	SCHRAUBE M6x12	TORNILLO M6x12
	9	E000P03904	1	COMMUTATORE SINISTRO	LEFT HANDLE SWITCH	COMMUTATEUR GAUCHE	UMSCHALTER LINKS	CONMUTADOR IZQUIERDO
	10	E000P03629	1	COMMUTATORE DESTRO	RIGHT SWITCH	COMMUTATEUR DROITE	UMSCHALTER RECHTS	CONMUTADOR DERECHO
	11	8000A1074	2	PIOLO IN GOMMA	RUBBER PIN	PLOT EN CAOUTCHOUC	GUMMIDÜBEL	CLAVIJA DE GOMA
	12	800060233	2	GOMMINO	RUBBER RING	JOINT EN CAOUTCHOUC	GUMMISCHEIBE	GOMA
	13	F000P03785	1	DISTANZIALE SUPERIORE REGOLAZIONE FARO	HEADLIGHT ADJUSTMENT TOP SPACER	ENTRETOISE SUPÉRIEURE RÉGLAGE PHARE	OBERES DISTANZSTÜCK SCHEINWERGEREINSTELLUNG	DISTANCIADOR SUPERIOR REGULACIÓN FARO
	14	F000P03786	1	DISTANZIALE INFERIORE REGOLAZIONE FARO	HEADLIGHT ADJUSTMENT BOTTOM SPACER	ENTRETOISE INFÉRIEURE RÉGLAGE PHARE	UNTERES DISTANZSTÜCK SCHEINWERGEREINSTELLUNG	DISTANCIADOR INFERIOR REGULACIÓN FARO
	15	F000P03798	1	VITE TCEI M8x20	SCREW TCEI M8x20	VIS TCEI M8x20	SCHRAUBE TCEI M8x20	TORNILLO TCEI M8x20
	16	Z00056377	1	ROSETTA	WASHER	RONDELLE	UNTERLEGSCHLEIBE	ARANDELA

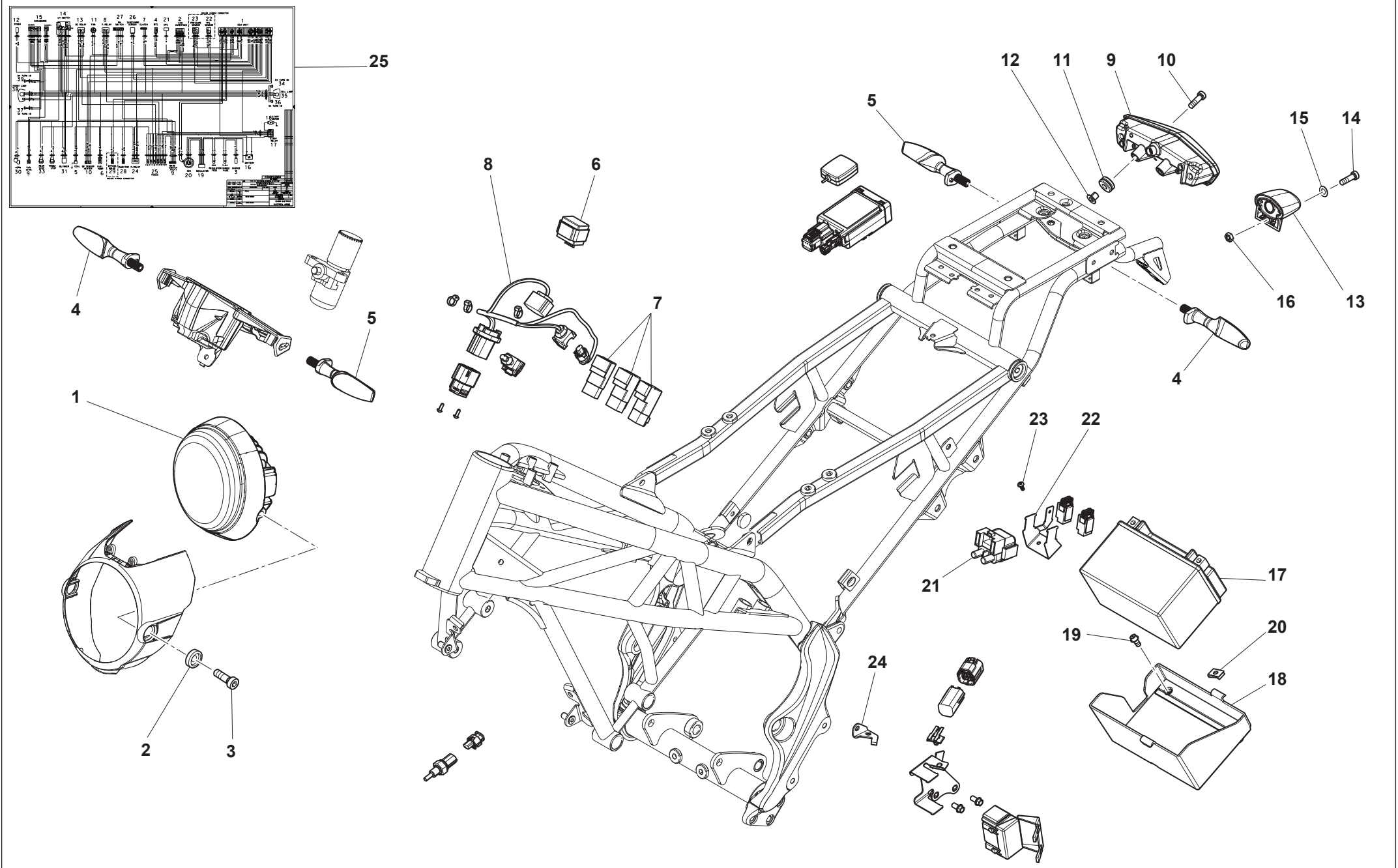

Note Notes Notes Marke Notas	Pos. No. N. Index Pos.	N. Cod. Code No. Nr. Code Code Nr N. Cod.	Q.tà Q.ty Q.te M.ge C.ad	DENOMINAZIONE	NAME	DESIGNATION	BESHREIBUNG	DENOMINACION
	1	EA00P02570	1	FANALE ANTERIORE COMPLETO	COMPLETE FRONT HEADLAMP	FEU AVANT COMPLET	FRONTSCHWEINWERFER KOMPLETT	FARO DELANTERO COMPLETO
	2	F000P03088	2	RONDELLA	SPACER	RONDELLE	UNTERLEGSCHEIBE	ARANDELA
	3	F000P03798	2	VITE TCEI RIBASSATA	NARROW SCREW TCEI	VIS TCEI SURBAISSÉE	ABGEFL. ZYL.KOPFSCHR. M. INNENSECHSK.	TORNILLO TCEI CABEZA BAJA
	4	E000P02279	2	INDICATORE ANT. DX E POST. SX	RH FRONT AND LH REAR TURN INDICATOR	CLIGNOTANT AV. DRT ET ARR. GCHE	VORDERER RE UND HINTERER LI BLINKER	INDICADOR DEL. DER. Y TRAS. IZQ.
	5	EA00P02279	2	INDICATORE ANT. SX E POST. DX	LH FRONT AND RH REAR TURN INDICATOR	CLIGNOTANT AV. GCHE ET ARR. DRT	VORDERER LI UND HI RECHTER BLINKER	INDICADOR DEL. IZQ. Y TRAS. DER.
	6	E000P02280	1	INTERMITTENZA	FLASHER	DISPOSITIF CLIGNOTANTS	BLINKGEBER	INTERMITENCIA
	7	8000A6749	3	RELÈ	RELAY	RELAIS	RELAIS	RELÉ
	8	E000P03097	1	CABLAGGIO AIRBOX	AIRBOX WIRING	CÂBLAGE BOÎTE À AIR	AIRBOX-VERKABELUNG	CABLEADO AIRBOX
	9	E000P03851	1	FANALE POSTERIORE	TAIL LIGHT	FEU ARRIÈRE	HECKSCHEINWERFER	PILOTO TRASERO
	10	60ND07335	2	VITE TCEI M6x16	SCREW TCEI M6x16	VIS TCEI M6x16	SCHRAUBE TCEI M6x16	TORNILLO TCEI M6x16
	11	F000P02917	2	GOMMINO ANTIVIBRANTE	SILENT-BLOCK	ANTIVIBRATION	SCHWINGUNGSDAMFER	ANTIVIBRADOR
	12	ZA0069429	2	BUSSOLA	BUSHING	DOUILLE	BUCHSE	CASQUILLO
	13	8000A0212	1	DISPOSITIVO ILLUMINAZIONE TARGA	NUMBER PLATE LIGHTING DEVICE	DISP. D'ÉCLAIR. PLAQUE D'IMMATR.	KENNZEICHENBELEUCHTUNGSVORRICHTUNG	DISPOSITIVO ILUMINACIÓN MATRÍCULA
	14	60ND02487	1	VITE TCEI M5x20	SCREW TCEI M5x20	VIS TCEI M5x20	SCHRAUBE TCEI M5x20	TORNILLO TCEI M5x20
	15	62ND15548	1	ROSETTA	WASHER	RONDELLE	UNTERLEGSCHEIBE	ARANDELA
	16	Z00061355	1	DADO AUTOBLOCCANTE M5	SELF-LOCKING NUT M5	ECROU AUTOBLOQUANT M5	SELBSTSICHERNDE MUTTER M5	TUERCA AUTOBLOCCANTE M5
	17	E000P02877	1	BATTERIA	BATTERY	BATTERIE	BATTERIE	BATERÍA
	18	F000P02878	1	SUPPORTO BATTERIA	BATTERY SUPPORT	SUPPORT BATTERIE	BATTERIE HALTERUNG	SOPORTE BATERÍA
	19	F000P03911	4	VITE AUTOFILETTANTE	SCREW, TAPPING	VIS TARAUD	GEWINDESCHRAUBE	TORNILLO AUTOROSCANTE
	20	8000H2168	2	DADO A GRAFFETTA M5	CLIP NUT M5	ECROU À AGRAFE M5	SICHERUNGSMUTTER M5	TUERCA DE CLIP M5
	21	E000P02437	1	TELERUTTORE AVVIAMENTO	SOLENOID STARTER	SOLENOÏDE DE DEMARRAGE	ANLASSER-FERNRELAIS	TELERRUPTOR ARRANQUE
	22	F000P03755	1	PIASTRINO SUPPORTO TELERUTTORE	SOLENOID STARTER SUPPORT PLATE	PLATINE DE SUPPORT SOLÉNOÏDE	AUFNAHMEPLÄTTCHEN FERNSCHALTER	PLACA SOPORTE TELERRUPTOR
	23	F000P03911	2	VITE AUTOFILETTANTE	SCREW, TAPPING	VIS TARAUD	GEWINDESCHRAUBE	TORNILLO AUTOROSCANTE
	24	F000P03994	1	PIASTRINA MASSA MOTORE	ENGINE GROUND PLATE	PLATINE MASSE MOTEUR	MOTORMASSENPLÄTTCHEN	PLACA MASA MOTOR
	25	E000P02869_P	1	CABLAGGIO	WIRING HARNESS	CÂBLAGE	VERKABELUNG	CABLEADO

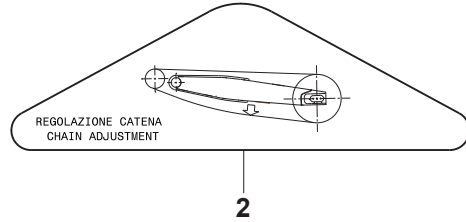

5
UNLEADED
FUEL ONLY

1

INFORMAZIONI IMPORTANTI
Pressione pneumatici a freddo

Solo guidatore	ANT.	Kg./cm ²	psi
	POST.	Kg./cm ²	psi
Guidat. e passegg.	ANT.	Kg./cm ²	psi
	POST.	Kg./cm ²	psi

